

CD-Pxx-00-0 Series

Duct Mount CO₂ Transmitter

Description

Johnson Controls offers a complete line of Carbon Dioxide (CO₂) transmitters for measuring and transmitting CO₂ levels, ranging from 0 to 2,000 parts per million (ppm), within Heating, Ventilating, and Air Conditioning (HVAC) applications. These compact, duct mounted devices offer a choice of 0 to 10 V or 0 to 20 mA output signals and feature an optional relay output with or without a digital display. Johnson Controls® CO₂ transmitters are easy to install and to operate.

The silicon-based CARBOCAP® sensor delivers high accuracy and long-term measurement stability (±100 ppm) over a five-year period without calibration. The diffusion-aspirated, single-beam, dual-wavelength sensor structure is remarkably simple. It consists of an infrared (IR) source, a sample cell, an IR detector, and a tunable interference filter that enables measurements at two wavelengths. Reference measurements made using a tunable interference filter eliminate the typical weakness of dual-beam sensors and permits shifting the optical pass band electronically. This innovative design provides precise reference readings that eliminate the typically broad deviation expected from a traditional CO₂ sensor.

Refer to the *CD-Pxx-00-1 Series Duct Mount CO₂ Transmitter Product Bulletin (LIT-216525)* for important product application information.

Features

- DCV strategies offer a potential for 10 to 70% energy savings
- CARBOCAP single-beam, dual-wavelength design provides superior performance compared to other technologies
- CARBOCAP silicon, micro-machined construction provides reliable CO₂ measurement in duct environments
- calibration reliability offers five years of reliable calibration
- adjustable duct probe depth permits optimal placement of sensing tip in a duct
- optional features offer relay output for fan control

Applications

The new CO₂ transmitters are easy to install, offer a full 3-year warranty, and require no maintenance or field calibration. They are designed to work:

- in standalone mode
- in support of Demand Control Ventilation (DCV)
- with fresh air and Indoor Air Quality (IAQ) systems
- as part of any integrated Building Automation System (BAS)
- with rooftop air handling Economizer controls systems
- connected to Metasys® system or the AD-DME series



Duct Mount Transmitter with Conduit Adaptor and Mounting Flange

Repair Information

If the CD-Pxx-00-0 Series Transmitter fails to operate within its specifications, replace the unit. For a replacement CO₂ transmitter, contact the nearest Johnson Controls® representative.

Selection Charts

CD-Pxx-00-0 Series Duct Mount CO₂ Transmitter

Code Number	Description
CD-P00-00-0	Duct Mount CO ₂ Transmitter
CD-PR0-00-0	Duct Mount CO ₂ Transmitter with Relay

Accessories

Code Number	Description
ACC-CD-S	Relay Setpoint Software Kit; includes software and interface cable to reset the On and Off relay setpoints for CD-PR0-00-0
Y65T31-0	Multiple Primary Transformer, 40 VA, 120/208/230 V Primary, 24 V Class 2 Secondary with Screw Terminals: Foot Mounting or 4 x 4 in. (101.6 x 101.6 mm) Plate

Maintenance Parts

Code Number	Description
ACC-CD-R	Relay Output Module for use in CD-PR0-00-0
ACC-CD-CFK1	Conduit Adaptor Kit

CD-Pxx-00-0 Series Duct Mount CO₂ Transmitter (Continued)

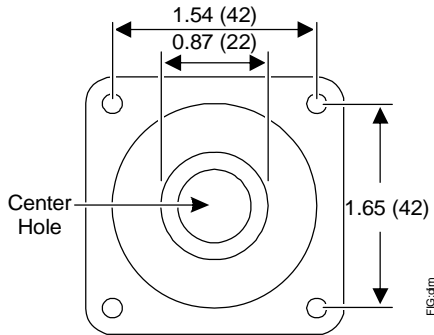

Mounting Flange Dimensions, in. (mm)

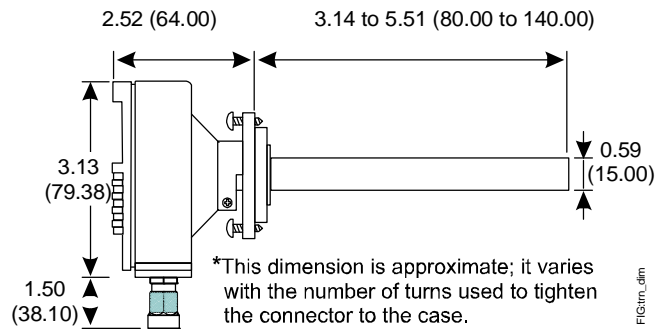

Transmitter Dimensions, in. (mm)

Technical Specifications

CD-Pxx-00-0 Series Duct Mount CO ₂ Transmitter		
Measuring Range	0 to 2,000 ppm CO ₂	
Accuracy at 77°F (25°C)	< ±[30 ppm CO ₂ + 2.0% of reading] (includes manufacturing deviation and drift). All accuracy specifications reflect testing the transmitters using high-grade, certified gases. Transmitters are intended for an altitude range of 0 to 1,969 ft (0 to 600 m) above sea level without compensation	
Non-Linearity	< 0.5% of Full Scale	
Temperature of Dependence of Output	< 0.56% of Full Scale/F° (<0.1% of Full Scale/C°)	
Long-Term Stability	< ±5.0% of Full Scale/5 Years	
Response Time (0 to 63%)	1 Minute	
Operating Temperature Range	23 to 113°F (-5 to 45°C)	
Storage Temperature Range	-4 to 158°F (-20 to 70°C)	
Humidity Range	0 to 85% non-condensing	
Transmitter Output Signal CO ₂	Jumper Selectable: 0 to 20 mA or 4 to 20 mA or 0 to 10 VDC (Default) Maximum Output Current: 25 mA; Maximum Output Voltage: 12.5 V Maximum 30 V, 0.5A, Class 2	
Recommended External Load	Current Output: Maximum 500 ohms Load Resistance Voltage Output: Minimum 1,000 ohms Load Resistance	
Power Supply Range	20 to 30 VAC (18 to 30 VDC), Class 2	
Power Consumption	< 2.5 W Average, 4.1 VA	
Warm-up Time	< 5 minutes	
Air Flow Range	0 to 7,500 ft/Minute (0 to 2,286 m/Minute)	
Duct Probe Material	Duct Probe Meets Plenum Rating Requirements of UL 1995, Heating and Cooling Equipment	
Housing Material	ABS Plastic	
Dimensions (H x W x D)	3-5/32 x 3-3/16 x 8 in. (80 x 81 x 204 mm)	
Shipping Weight	0.3 lb (140g)	
Compliance	United States	UL Listed, CCN XAPX
	Canada	UL, Llisted XAPX7
	Europe	CE Mark – Johnson Controls, Inc., declares that the CD-Pxx-00-0 Duct Mount CO ₂ Transmitters are in compliance with the essential requirements and other relevant provisions of the EMC Directive 2004/108/EC