

GL-CO-RFG65x

1, 2 or 3-Channel Gas Leak Alarm Systems



Features:

- Remote sensors for natural gas, LPG and CO
- 2 x SPST relay outputs
- DIN-rail as standard, panel or wall mounting kits available
- Adjustable alarm thresholds

Benefits:

- Self-diagnosis fault system
- Audio & visual alarms

Technical Overview

The CL-CO-RFG65x is a series of gas leak alarm systems, that are designed for the detection of gas leaks in spaces such as boiler plant rooms, workshops and other industrial gas installations, to provide safety alarm and shutdown facilities on detection of gas leakage. 1, 2 or 3 channel versions are available.

Specification:

Power supply:	230Vac \pm 10% @ 50/60Hz 12V \pm 10%
Power consumption	7VA
Radio disturbance	VDE0875/0871
Vibration test	with 2g (DIN 40046)
Relay outputs	2 x SPDT, 250V @ 5 (1) A
Housing dimensions	105 x 115 x 70mm
Housing materials:	
Cover	ABS
Base	Nylon
Housing protection	IP40
Panel mount housing dim.	142 x 142 x 125mm (5.59 x 5.59 x 4.92")
Sensor dimensions	77 x 77 x 44 (3.03 x 3.03 x 1.73")
Sensor material	Nylon
Sensor protection	IP44
Ambient:	
Storage temp.	-25 to + 60°C (-13 to 140°F)
Operating temp.	0 to 45°C (32 to 113°F)
RH	Class F Din 40040
Country of origin	Italy

Part Codes:

Controllers

GL-CO-RFG651

1 Channel gas leak alarm system (DIN rail mount)

GL-CO-RFG652

2 Channel gas leak alarm system (DIN rail mount)

GL-CO-RFG653

3 Channel gas leak alarm system (DIN rail mount)

Mounting options

GL-CO-WMK6

Wall mounting kit

GL-CO-FMK6

Panel mounting kit

Sensors

GL-CO-SRS150

Natural gas sensor

GL-CO-SRS250

LPG, Propane sensor

GL-CO-SRS350

Carbon Monoxide sensor



The products referred to in this data sheet meet the requirements of EU 2004/108/EC and 2006/95/EC

Siting of Devices:

Detectors

These must be sited in a dry space which meets the relevant ambient requirements given on page 2.

If installed in a location classified as "Hazardous" it must be installed in a cabinet for electrical equipment constructed according to the regulations in force for the class of danger concerned.

The controller can be mounted on a DIN rail and housed in a standard DIN enclosure.

Sensors

The correct siting of the sensor is fundamental for the correct functioning of the system. The position depends on the type of gas to be monitored and, in particular, on its density in respect of air:

- **Methane** (gas lighter than air which therefore tends to rise).
Position: at a distance of 10 to 50cm from the ceiling and, in any event, above doors or windows.
- **Propane (LPG)** (gas heavier than air and so tends to move downwards).
Position: at a distance of 10 to 50cm from the floor.
- **Carbon monoxide (CO)** (gas with a density very similar to that of air and which therefore tends to diffuse uniformly)
Position: at a height of 150 to 200cm from floor.

Moreover, to ensure the correct operation of the detector and to avoid useless alarms due to a casual and momentary presence of gas, the sensor must **NOT** be positioned:

- Less than 1 to 2 metres from boilers or water heaters,
- Less than 2 to 3 metres from kitchen ranges and ovens,
- In spaces where air movement could be hindered (e.g. in corners or enclosed spaces),
- Near to doors or windows,
- Near to air extractors,
- In places where dust or dirt could contaminate the sensor and so render it ineffective,
- In places subject to possible sprays of water, particularly sensors positioned near the floor,
- In places where the temperature or humidity could be outside the limits stated on page 2.

Solenoid shut-off valve

- This must be installed on the gas distribution pipe, taking the following precautions::
- If possible, in a different space from the one being controlled,
- In an easily-accessible place, especially for the valves which have to be reset manually.
- If installed outside, it must be protected against the weather,
- In installations with external propane (LPG) gas tank, it must be installed downstream of the pressure-reducing valve (30 to 40 mbar).

Alarm Levels:

(In bold type threshold with Sensitivity = 0)

Methane

- Alarm methane 0.5...**0.8**...1.25 %
5,000...**8,000**...12,500 ppm
- Pre-alarm methane 0.3...**0.5**...0.8 %
3,000...**5,000**...8,000 ppm

Propane-GPL

- Alarm propane-LPG 0.22...**0.35**...0.56 %
2,200...**3,500**...5,600 ppm
- Pre-alarm propane-LPG 0.14...**0.22**...0.35 %
1,400...**2,200**...3,500 ppm

Carbon monoxide (CO)

Warning: in detecting carbon monoxide (CO), the levels and intervention times are processed and controlled by a microprocessor. The "Sensitivity" control must be set in the "0" position.

- Carbon monoxide-CO alarm: "threshold + time"
< 50 ppm: no alarm
50...100 ppm: 60 minutes
100...300 ppm: 10 minutes
>300 ppm: immediate alarm
- Carbon monoxide-CO pre-alarm:
Time between exceeding alarm threshold and alarm

Installation:

1. The GL-CO-RFG65x should only be installed by a competent, suitably trained technician, experienced in installation with hazardous voltages. (>50Vac & <1000Vac or >75Vdc & 1500Vdc)
2. Ensure that all power is disconnected before carrying out any work on the GL-CO-RFG365x.
3. Maximum cable is 2.5mm², care must be taken not to over tighten terminals.
4. Separate the base from the cover.
5. If DIN rail mounting clip onto the DIN rail.
6. Make connections as required using the following cables:
 - 1.5 mm² cross-section for power and relay control outputs,
 - 1 mm² cross-section for sensors positioned up to a maximum distance of 50 meters; or
 - 1.5 mm² cross-section for sensors positioned up to a maximum distance of 75 meters.NB It is advised that no more than 2 cables be inserted into a single terminal. Use external junction boxes if necessary.
7. Select the "link functions" to adapt the detector to the desired type of operational control.
8. Replace the cover on the base using the 4 screws provided, if panel mounting fix to panel door, using the panel mounting kit (panel cut out 138 x 138 ±0.5%).

Fascia & Wiring:

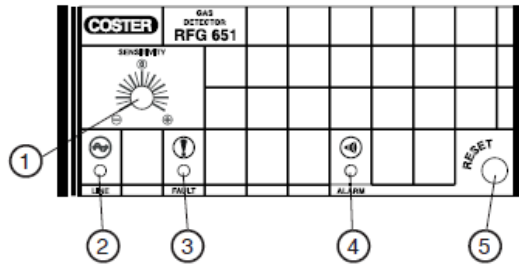

- 1 Sensitivity potentiometer
- 2 Power supply LED
- 3 Fault LED(s)
- 4 Alarm LED(s)
- 5 Reset button

Example:

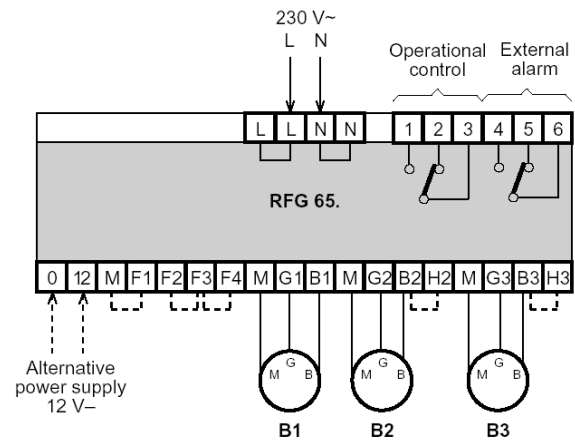

Links:

Warning, when changing link functions ensure all power is disconnected first.

Link Functions:

M - F1

No link Internal buzzer enabled
Linked Internal buzzer disabled

F3 - F4

No link Relay with latching alarm
Linked Relay with non-latching alarm

F2 - F3

No link Relay normally energised when no gas present
Linked Relay normally de-energised when no gas present

B2 - H2

linked B2 sensor not connected

B3 - H3

Linked B3 sensor not connected

Operational relay output (when in alarm):

F2 - F3 1-3 closes 2-3 opens

F2 - F3 1-3 opens, 2-3 closes

Latching alarm & reset:

F3 - F4 linked:

Alarm ceases when the gas concentration falls below the threshold level and the ALARM LED blinks slowly. Press the RESET button to clear the LED status.

F3 - F4 unlinked:

Alarm continues even when the gas concentration falls below the threshold level. To deactivate press the RESET button for at least 5 seconds.

Operation:

Switching on

When it is powered the GL-CO-RFG does not start detecting immediately and does not signal any alarm for the first two minutes of operation.

This is the time necessary for the gas-sensing elements to become stabilised so that their readout can be considered accurate and reliable. This period for the stabilisation of the sensors is indicated, on the fascia of the detector by the flashing of the FAULT and ALARM LEDs. At the end of the stabilisation period the FAULT and ALARM LEDs, in normal situations, switch off.

Type of Fault	Fault LED	Alarm LED
Sensor self-heating element broken	ON	OFF
No connection to terminal G	ON	OFF
No connection to terminal B	ON	OFF
No connection to terminal M	OFF	ON
Connections G & B reversed	ON	OFF
Connections G & M reversed	OFF	ON
Connections B & M reversed	OFF	ON

Pre-alarm and alarm thresholds for methane and propane-LPG)

By means of the SENSITIVITY knob, the intervention threshold (sensitivity) can be increased or decreased according to the particular conditions of the space in which the sensor is positioned, or for specific requirements:

- Knob towards + = increase of sensitivity.
- Knob towards - = decrease of sensitivity.

These adjustments, however, remain within the limits required by the regulations so it is always possible to intervene under conditions of the maximum safety.

The intervention levels, referred to the LEL (Lower limit of Explosivity) = volumetric ratio in air of combustible gas or vapour below which an explosive mixture is not formed) for the gases methane and propane LPG are as follows (the threshold values with the "SENSITIVITY" knob = 0 are shown in bold type):

Type of gas	LIE	Pre-Alarm	Alarm threshold
Methane	5%	0.2.. 0.5 ..0.8%	0.5.. 0.8 ..1.25%
	50000ppm	3000.. 5000 ..8000ppm	5000.. 8000 ..12500ppm
Propane (LPG)	2.10%	0.14.. 0.22 ..0.35%	0.22.. 0.35 ..1.25%
	21000ppm	1400.. 2200 ..3500ppm	2200.. 3500 ..5600ppm

Pre-alarm and alarm threshold for carbon monoxide (CO)

The danger of carbon monoxide (CO) does not derive from its inflammability or the danger of explosion, but from its very high toxicity to the human body. Moreover, its danger does not depend only on the concentration of the gas in air, but also on the length of time a person has remained in an atmosphere in which this gas is present.

The pre-alarm and alarm levels of the sensor are determined by the processing of a microprocessor which takes into account the concentration of the gas in the air and the exposure time. For this reason the "Sensitivity" knob on the detector must not influence the sensor readout and, even if there is only one carbon monoxide (CO) sensor, it must be set in "0" position.

If the pre-alarm threshold is exceeded, this is indicated, on the detector fascia, by the intermittent lighting of the ALARM LED for the sensor which has detected the anomaly.

Operation (continued):

The intervention modes of the detector are accordingly as follows:

- **Concentration < 0.005%** (50 ppm): the safety of the persons is guaranteed for an indefinite length of time and so the detector does not intervene,
- **Concentration 0.005...0.01%** (50...100 ppm): within this concentration range, for 60 minutes the detector signals a "Pre-alarm" situation and after this period switches to "Alarm".
- **Concentration 0.01...0.03%** (100...300 ppm): within this concentration range, for 10 minutes the detector signals a "Pre-alarm" situation and after this period switches to "Alarm".
- **Concentration > 0.03%** (300 ppm): the safety of the persons present in the space is not guaranteed. The detector immediately switches to the "Alarm" state. The concentration values and times taken into consideration by the detector have been established allowing a large safety margin to ensure there is no danger to the persons.

The action of the detector is of the "Dynamic" type: if the concentration passes from one level to another, the time calculated increases or decreases as a consequence, thereby modifying the response of the detector. In particular, should the concentration of carbon monoxide (CO) return below 0.005% (50 ppm) for more than one minute, the detector returns to the "Normal" condition, cancelling all the times counted up to that moment and, if it has been programmed "Without latching" any "Alarm" condition will be terminated.

Commissioning:

- Power the device: LINE LED lights and FAULT LED and ALARM LED flash.
- After 1.5...2 minutes the detector is enabled to acquire alarms and the LEDs FAULT and ALARM should go out.
- Position the SENSITIVITY knob on "0".
- Since the sensors are selective, and so not influenced by gases other than that for which they are dedicated, to simulate the presence of gas it is necessary to use small gas cylinders containing specific gases at preset concentrations, releasing the gas as near as possible to the detecting sensor. Only for sensors for detecting propane (LPG) can gas from a normal cigarette lighter be used.
- When the gas concentration exceeds the pre-alarm threshold the ALARM LED flashes.
- With a delay (about 20 seconds) after exceeding the alarm threshold:
 - ALARM LED lights and stays lit.
 - The internal alarm and the outside warnings (only if without jumper M-F1) are switched on.
 - The operational relay closes the gas shut-off valve or switches on the aeration fan.
- Stop erogation of gas. When gas concentration on the sensor returns below the threshold level:
 - If detector is "without latching" (with jumper between F3-F4), alarm ceases and ALARM LED remains flashing slowly until RESET button is pushed
 - If detector is "with latching" (without jumper between F3-F4), alarm remains until RESET button is pressed for at least 5 seconds.
- If the detector controls a valve with manual reset, it is necessary to re-open manually also the valve.

Whilst every effort has been made to ensure the accuracy of this specification, Sontay cannot accept responsibility for damage, injury, loss or expense from errors or omissions. In the interest of technical improvement, this specification may be altered without notice.

Tel: +44 (0)1732 861200. - E-mail: sales@sontay.com. - Web: www.sontay.com.

© 2012 Sontay Limited. All rights reserved