

VG1000 Series Forged Brass Ball Valves

Product Bulletin

Code No. LIT-977132
 Issued July 6, 2011
 Supersedes August 27, 2008

Refer to the [QuickLIT Web site](#) for the most up-to-date version of this document.

VG1000 Series Ball Valves are designed to regulate the flow of hot or chilled water and, for some models, low pressure steam in response to the demand of a controller in Heating, Ventilating, and Air Conditioning (HVAC) systems. Available in sizes 1/2 through 2 in. (DN15 through DN50), this family of two- and three-way forged brass valves is factory or field mounted to Johnson Controls® VA9104, M9106, M9109, and M9100 Series Non-Spring Return and VA9203 and VA9208 Series Spring Return Electric Actuators for on/off, floating, or proportional control. For sweat and press end connection valves supplied with an actuator, the actuator is not mounted to the valve to allow access to the end connections.



Figure 1: VG1000 Series Ball Valves Shown with Factory-Mounted M9000 Series Electric Actuators

Table 1: Features and Benefits (Part 1 of 2)

Features	Benefits
National Pipe Thread (NPT), Sweat, and Press End Connections	Provide the right valve for a broad range of applications, reduce installation time while reducing the need for adapters, and increase system reliability.
Forged Brass Body	Provides 580 psig static pressure rating.
Amodel® Flow Characterizing Disk	Maintains equal percentage flow characteristics for best temperature control, available in a wide variety of Cvs to cover a broad range of applications.
200 psi Closeoff Pressure Rating	Provides tight shutoff.
Chrome-Plated Brass Ball and Stem Assembly Standard	Handles both chilled and hot water applications with a fluid temperature range of 23 to 203°F (-5 to 95°C).
300 Series Stainless Steel Ball and Stem Assembly	Tolerates high temperature water or 15 psi saturated steam with fluid temperatures of -22 to 284°F (-30 to 140°C) or where a higher degree of corrosion protection is desired.
500:1 Rangeability	Provides accurate control under all load conditions.
Ethylene Propylene Diene Monomer (EPDM) Double O-Ring Stem Seal	Provides a leak-free seal; the packing has been tested and is leak-free after 200,000 cycles in iron-oxide contaminated water.

Table 1: Features and Benefits (Part 2 of 2)

Features	Benefits
Graphite-Reinforced Polytetrafluoroethylene (PTFE) Seats	Include 15% graphite-reinforced ball seals, providing better wear resistance.
Blowout-Proof Stem	Protects the user from the risk of injury.
Maintenance-Free Design	Performs without failure in excess of 200,000 full stroke cycles in iron-oxide contaminated water.
Wide Selection of Styles for a Variety of Applications	Offers various valve configurations including two- and three-way full port and reduced port models in chrome-plated brass and stainless steel trim.
Factory-Mounted VA9104, M9106, M9109, VA9203 or VA9208 Series Electric Actuators	Reduce installation time, thus reducing overall installation cost.
M9000-520 Linkage Kit Available for Field Mounting to M9106 or M9109 Series Electric Actuators	Reduces installation time, thus reducing overall installation cost; and provides superior thermal isolation between the valve and actuator.
M9000-551 Linkage Kit Available for Field Mounting to M9104 Series Electric Actuators	Lowers both space requirements and total cost by providing high thermal isolation in a compact size.
M9000-560 Linkage Kit Available for Field Mounting to M9203 or M9208 Series Electric Actuators	Lowers both space requirements and total cost by providing high thermal isolation in a compact size.
M9000-561 Thermal Barrier Kit for Extending M(VA)9104, M(VA)9203, and M(VA)9208 Series Electric Spring Return Actuators	Allows the valve assembly to be used for fluid temperatures up to 284°F (140°C), or 15 psi (105 kPa) saturated steam.
M9000-341 Weather Shield Kit Available for Field Mounting M(VA)9104, M(VA)9203, and M(VA)9208 Series Electric Spring Return Actuators	Protects the electric actuators from corrosion, rain, freezing rain, sleet and snow. The M9000-341 Weather Shield Kit is manufactured to National Electrical Manufacturers' Association (NEMA) 4X (IP66/67).

Ordering Information

Table 2: Ordering Data¹

V	G	Valve Global													
1	2	1	Product		1 = Forged Brass Ball Valve										
		3	Family												
		2	Body Type and Flow Characteristic		2 = Two-Way, with Equal Percentage Flow Characteristics										
		4			8 = Three-Way Mixing, with Equal Percentage Flow Characteristics of In-line Port and Linear Flow Characteristics of Angle-Port										
		4	End Connection		4 = Threaded - NPT Taper										
		5			7 = Sweat (1/2 to 1 in. Sizes)										
					9 = Press (ProPress® Fitting Compatible, 1/2 to 1 in. Sizes) Press End Connections are designed to work with RIDGID® Pressing Tools.										
		1	Trim		1 = Chrome-Plated Brass Ball and Nickel-Plated Brass Stem										
		6			5 = Stainless Steel Ball and Stem, 300 Series										
		A	E	Size and Maximum Cv	Size	Control Disk	Control Port Cv (kv)	Bypass Port Cv (kv) (Three-Way Only)							
		7	8	(kv = Cv x 0.857)	AD = 1/2 in. (DN15)	Yes	1.2 (1.0)	0.7 (0.6)							
					AE = 1/2 in. (DN15)	Yes	1.9 (1.6)	1.2 (1.0)							
					AF = 1/2 in. (DN15)	Yes	2.9 (2.5)	1.9 (1.6)							
					AG = 1/2 in. (DN15)	Yes	4.7 (4.0)	2.9 (2.5)							
					AL = 1/2 in. (DN15)	Yes	7.4 (6.3)	4.7 (4.0)							
					AN = 1/2 in. (DN15) ²	No	11.7 (10.0)	5.8 (5.0)							
					BG = 3/4 in. (DN20)	Yes	4.7 (4.0)	2.9 (2.5)							
					BL = 3/4 in. (DN20)	Yes	7.4 (6.3)	4.7 (4.0)							
					BN = 3/4 in. (DN20) ²	No	11.7 (10.0)	5.8 (5.0)							
					CL = 1 in. (DN25)	Yes	7.4 (6.3)	4.7 (4.0)							
					CN = 1 in. (DN25)	Yes	11.7 (10.0)	7.4 (6.3)							
					CP = 1 in. (DN25) ²	No	18.7 (16.0)	9.4 (8.0)							
					DN = 1-1/4 in. (DN32)	Yes	11.7 (10.0)	7.4 (6.3)							
					DP = 1-1/4 in. (DN32)	Yes	18.7 (16.0)	11.7 (10.0)							
					DR = 1-1/4 in. (DN32) ²	No	29.2 (25.0)	14.6 (12.5)							
					EP = 1-1/2 in. (DN40)	Yes	18.7 (16.0)	11.7 (10.0)							
					ER = 1-1/2 in. (DN40)	Yes	29.2 (25.0)	18.7 (16.0)							
					ES = 1-1/2 in. (DN40) ²	No	46.8 (40.0)	23.4 (20.0)							
					FR = 2 in. (DN50)	Yes	29.2 (25.0)	18.7 (16.0)							
					FS = 2 in. (DN50)	Yes	46.8 (40.0)	29.2 (25.0)							
					FT = 2 in. (DN50) ²	No	73.7 (63.0)	36.8 (31.5)							
		+	Actuator		+ = Factory-Mounted Actuator										
		9	Mounting		(Leave Fields 9 through 15 blank for valve without factory-mounted actuator.) H = High Temperature Linkage (VA9104, VA9203, and VA9208 actuators)										
1	2	3	4	5	6	7	8	9	10	11	12	13	14	15	= Field
V	G	1	2	4	1	A	E	+							
Valve								+ Actuator							

Example: Forged brass ball valve, two-way, threaded (NPT), brass trim, equal %, 1/2 in. (DN15) 1.9 Cv.

1. Before retrofitting older valves with VA9104, M9104, VA9203, or VA9208 actuators, be sure that the valves have a tapped hole in the center of the valve stem and no threads in the flange holes. These direct mount actuators do not fit older valves designed without a tapped center stem hole or with threaded flange mounting holes.
2. Indicates model without characterizing disk.

See Table 3 to determine the correct factory-mounted actuator, where needed.

Table 3: Ordering Data – Adding a Factory-Mounted Electric Actuator¹

V	G	1	2	4	1	A	E	+							
									9	Actuator		+ = Factory-Mounted Actuator H = High Temperature Linkage (VA9104, VA9203, and VA9208 actuators)			
									9	Mounting		(Leave Fields 9 through 15 blank for valve without factory-mounted actuator.)			
									9	Actuator		9 = Direct Acting M9000 or VA9000 Series Actuator			
									10	Series					
									0	6	Actuator Size ²		06 = M9106-xGx-2 (1/2, 3/4, 1, 1-1/4, and 1-1/2 in. NPT Valves)		
									11	12			09 = M9109-xGx-2 (2 in. Valves Only)		
													23 = VA9203-xxx-2(Z) Spring Opens		
													28 = VA9208-AGA-2 and VA9208-GGA-2 Spring Opens		
													43 = VA9203-xxx-2(Z) Spring Closes		
													48 = VA9208-AGA-2 and VA9208-GGA-2 Spring Closes		
													38 = VA9208-xxx-3 Spring Opens (available in AGC, BAA, BAC, BGA, BGC, and GGC)		
													58 = VA9208-xxx-3 Spring Closes (available in AGC, BAA, BAC, BGA, BGC, and GGC)		
													A4 = VA9104-xGA-2S, Non-Spring Return, 120 in. Cable (All 1/2, 3/4, and 1 in. Valves)		
													T4 = VA9104-xGA-3S, Non-Spring Return, Screw Terminals (All 1/2, 3/4, and 1 in. Valves)		
									G	Control Type		A = Floating, AC/DC 24 V Input (VA9104, M9106, M9109, VA9203, and VA9208)			
									13			B = On/Off (VA9203 and VA9208)			
													G = Prop. DC 0 (2) to 10 V or 0 (4) to 20 mA (M9106, M9109, VA9104, VA9203, and VA9208)		
													I = On/Off Floating with Timeout (VA9104, M9106, and M9109)		
									G	Supply		A = AC 120 V (VA9208-BAx Only)			
									14	Voltage		G = 24 VAC (All Models)			
													U = AC 85 to 264 V (VA9203-BUx Only)		
									C	Auxiliary Switch		A = No Auxiliary Switch (All models)			
									15			B = One Auxiliary Switch			
													C = Two Auxiliary Switches		
1	2	3	4	5	6	7	8	9	10	11	12	13	14	15	= Field
V	G	1	2	4	1	A	E	+	9	0	6	G	G	C	
Valve									+ Actuator						
<p>Example: Forged brass ball valve, two-way, threaded (NPT), brass trim, equal %, 1/2 in. (DN15) 1.9 Cv, factory-mounted direct acting M9106-GGC-2 Actuator, non-spring return, proportional control, AC 24 V supply (with feedback), and two-way auxiliary switches</p>															

1. Before retrofitting older valves with VA9104, M9104, VA9203, or VA9208 actuators, be sure that the valves have a tapped hole in the center of the valve stem and no threads in the flange holes. These direct mount actuators do not fit older valves designed without a tapped center stem hole or with threaded flange mounting holes.
2. Refer to actuator product bulletin for detailed information.

Table 4: Two-Way Stainless Steel Trim Ball Valves, Non-Spring Return, VA9104 Actuators without Switches

Fluid Temperatures: -4 to 212°F (-20 to 100°C) Not Rated for Steam Service				AC 24 V		
				On/Off (Floating) without Timeout ¹	On/Off (Floating) with Timeout	0 to 10 VDC Proportional
Valve	Size, in.	Cv	Closeoff psig			
Actuators with M3 Screw Terminals				VA9104-AGA-3S	VA9104-IGA-3S	VA9104-GGA-3S
VG1245AD	1/2	1.2 ²	200	VG1245AD+9T4AGA	VG1245AD+9T4IGA	VG1245AD+9T4GGA
VG1245AE		1.9 ²		VG1245AE+9T4AGA	VG1245AE+9T4IGA	VG1245AE+9T4GGA
VG1245AF		2.9 ²		VG1245AF+9T4AGA	VG1245AF+9T4IGA	VG1245AF+9T4GGA
VG1245AG		4.7 ²		VG1245AG+9T4AGA	VG1245AG+9T4IGA	VG1245AG+9T4GGA
VG1245AL		7.4 ²		VG1245AL+9T4AGA	VG1245AL+9T4IGA	VG1245AL+9T4GGA
VG1245AN		11.7		VG1245AN+9T4AGA	VG1245AN+9T4IGA	VG1245AN+9T4GGA
VG1245BG	3/4	4.7 ²	200	VG1245BG+9T4AGA	VG1245BG+9T4IGA	VG1245BG+9T4GGA
VG1245BL		7.4 ²		VG1245BL+9T4AGA	VG1245BL+9T4IGA	VG1245BL+9T4GGA
VG1245BN		11.7		VG1245BN+9T4AGA	VG1245BN+9T4IGA	VG1245BN+9T4GGA
VG1245CL	1	7.4 ²	200	VG1245CL+9T4AGA	VG1245CL+9T4IGA	VG1245CL+9T4GGA
VG1245CN		11.7 ²		VG1245CN+9T4AGA	VG1245CN+9T4IGA	VG1245CN+9T4GGA
VG1245CP		18.7		VG1245CP+9T4AGA	VG1245CP+9T4IGA	VG1245CP+9T4GGA
Actuators with 120 in. (3.05 m) 18 AWG Plenum Cable				VA9104-AGA-2S	VA9104-IGA-2S	VA9104-GGA-2S
VG1245AD	1/2	1.2 ²	200	VG1245AD+9A4AGA	VG1245AD+9A4IGA	VG1245AD+9A4GGA
VG1245AE		1.9 ²		VG1245AE+9A4AGA	VG1245AE+9A4IGA	VG1245AE+9A4GGA
VG1245AF		2.9 ²		VG1245AF+9A4AGA	VG1245AF+9A4IGA	VG1245AF+9A4GGA
VG1245AG		4.7 ²		VG1245AG+9A4AGA	VG1245AG+9A4IGA	VG1245AG+9A4GGA
VG1245AL		7.4 ²		VG1245AL+9A4AGA	VG1245AL+9A4IGA	VG1245AL+9A4GGA
VG1245AN		11.7		VG1245AN+9A4AGA	VG1245AN+9A4IGA	VG1245AN+9A4GGA
VG1245BG	3/4	4.7 ²	200	VG1245BG+9A4AGA	VG1245BG+9A4IGA	VG1245BG+9A4GGA
VG1245BL		7.4 ²		VG1245BL+9A4AGA	VG1245BL+9A4IGA	VG1245BL+9A4GGA
VG1245BN		11.7		VG1245BN+9A4AGA	VG1245BN+9A4IGA	VG1245BN+9A4GGA
VG1245CL	1	7.4 ²	200	VG1245CL+9A4AGA	VG1245CL+9A4IGA	VG1245CL+9A4GGA
VG1245CN		11.7 ²		VG1245CN+9A4AGA	VG1245CN+9A4IGA	VG1245CN+9A4GGA
VG1245CP		18.7		VG1245CP+9A4AGA	VG1245CP+9A4IGA	VG1245CP+9A4GGA

1. To avoid excessive wear or drive time on the motor for the AGx models, use a controller or software that provides a timeout function to remove the signal at the end of rotation (stall).
2. Cv has a characterizing risk.

Table 5: Two-Way Stainless Steel Trim Ball Valves, Non-Spring Return, VA9104 Actuators without Switches with Optional M9000-561 Thermal Barrier

Fluid Temperatures: -22 to 284°F (-30 to 140°C) Water and 15 psi Saturated Steam				AC 24 V		
				On/Off (Floating) without Timeout ¹	On/Off (Floating) with Timeout	DC 0 to 10 V Proportional
Valve	Size, in.	Cv	Closeoff psig			
Actuators with M3 Screw Terminals				VA9104-AGA-3S	VA9104-IGA-3S	VA9104-GGA-3S
VG1245AD	1/2	1.2 ²	200	VG1245ADH9T4AGA	VG1245ADH9T4IGA	VG1245ADH9T4GGA
VG1245AE		1.9 ²		VG1245AEH9T4AGA	VG1245AEH9T4IGA	VG1245AEH9T4GGA
VG1245AF		2.9 ²		VG1245AFH9T4AGA	VG1245AFH9T4IGA	VG1245AFH9T4GGA
VG1245AG		4.7 ²		VG1245AGH9T4AGA	VG1245AGH9T4IGA	VG1245AGH9T4GGA
VG1245AL		7.4 ²		VG1245ALH9T4AGA	VG1245ALH9T4IGA	VG1245ALH9T4GGA
VG1245AN		11.7		VG1245ANH9T4AGA	VG1245ANH9T4IGA	VG1245ANH9T4GGA
VG1245BG	3/4	4.7 ²	200	VG1245BGH9T4AGA	VG1245BGH9T4IGA	VG1245BGH9T4GGA
VG1245BL		7.4 ²		VG1245BLH9T4AGA	VG1245BLH9T4IGA	VG1245BLH9T4GGA
VG1245BN		11.7		VG1245BNH9T4AGA	VG1245BNH9T4IGA	VG1245BNH9T4GGA
VG1245CL	1	7.4 ²	200	VG1245CLH9T4AGA	VG1245CLH9T4IGA	VG1245CLH9T4GGA
VG1245CN		11.7 ²		VG1245CNH9T4AGA	VG1245CNH9T4IGA	VG1245CNH9T4GGA
VG1245CP		18.7		VG1245CPH9T4AGA	VG1245CPH9T4IGA	VG1245CPH9T4GGA
Actuators with 120 in. (3.05 m) 18 AWG Plenum Cable				VA9104-AGA-2S	VA9104-IGA-2S	VA9104-GGA-2S
VG1245AD	1/2	1.2 ²	200	VG1245ADH9A4AGA	VG1245ADH9A4IGA	VG1245ADH9A4GGA
VG1245AE		1.9 ²		VG1245AEH9A4AGA	VG1245AEH9A4IGA	VG1245AEH9A4GGA
VG1245AF		2.9 ²		VG1245AFH9A4AGA	VG1245AFH9A4IGA	VG1245AFH9A4GGA
VG1245AG		4.7 ²		VG1245AGH9A4AGA	VG1245AGH9A4IGA	VG1245AGH9A4GGA
VG1245AL		7.4 ²		VG1245ALH9A4AGA	VG1245ALH9A4IGA	VG1245ALH9A4GGA
VG1245AN		11.7		VG1245ANH9A4AGA	VG1245ANH9A4IGA	VG1245ANH9A4GGA
VG1245BG	3/4	4.7 ²	200	VG1245BGH9A4AGA	VG1245BGH9A4IGA	VG1245BGH9A4GGA
VG1245BL		7.4 ²		VG1245BLH9A4AGA	VG1245BLH9A4IGA	VG1245BLH9A4GGA
VG1245BN		11.7		VG1245BNH9A4AGA	VG1245BNH9A4IGA	VG1245BNH9A4GGA
VG1245CL	1	7.4 ²	200	VG1245CLH9A4AGA	VG1245CLH9A4IGA	VG1245CLH9A4GGA
VG1245CN		11.7 ²		VG1245CNH9A4AGA	VG1245CNH9A4IGA	VG1245CNH9A4GGA
VG1245CP		18.7		VG1245CPH9A4AGA	VG1245CPH9A4IGA	VG1245CPH9A4GGA

1. To avoid excessive wear or drive time on the motor for the AGx models, use a controller or software that provides a timeout function to remove the signal at the end of rotation (stall).
2. Cv has a characterizing risk.

Table 6: Two-Way Stainless Steel Trim Ball Valves, Non-Spring Return, M9106/M9109 Actuators without Switches

Fluid Temperatures: -22 to 284°F (-30 to 140°C) Water and 15 psi Saturated Steam				AC 24 V		
				On/Off (Floating) without Timeout ¹	On/Off (Floating) with Timeout	DC 0 to 10 V Proportional
Valve	Size, in.	Cv	Closeoff psig	M9106-AGA-2 M9109-AGA-2	M9106-IGA-2	M9106-GGA-2 M9109-GGA-2
VG1245AD	1/2	1.2 ²	200	VG1245AD+906AGA	VG1245AD+906IGA	VG1245AD+906GGA
VG1245AE		1.9 ²		VG1245AE+906AGA	VG1245AE+906IGA	VG1245AE+906GGA
VG1245AF		2.9 ²		VG1245AF+906AGA	VG1245AF+906IGA	VG1245AF+906GGA
VG1245AG		4.7 ²		VG1245AG+906AGA	VG1245AG+906IGA	VG1245AG+906GGA
VG1245AL		7.4 ²		VG1245AL+906AGA	VG1245AL+906IGA	VG1245AL+906GGA
VG1245AN		11.7		VG1245AN+906AGA	VG1245AN+906IGA	VG1245AN+906GGA
VG1245BG	3/4	4.7 ²	200	VG1245BG+906AGA	VG1245BG+906IGA	VG1245BG+906GGA
VG1245BL		7.4 ²		VG1245BL+906AGA	VG1245BL+906IGA	VG1245BL+906GGA
VG1245BN		11.7		VG1245BN+906AGA	VG1245BN+906IGA	VG1245BN+906GGA
VG1245CL	1	7.4 ²	200	VG1245CL+906AGA	VG1245CL+906IGA	VG1245CL+906GGA
VG1245CN		11.7 ²		VG1245CN+906AGA	VG1245CN+906IGA	VG1245CN+906GGA
VG1245CP		18.7		VG1245CP+906AGA	VG1245CP+906IGA	VG1245CP+906GGA
VG1245DN	1-1/4	11.7 ²	200	VG1245DN+906AGA	VG1245DN+906IGA	VG1245DN+906GGA
VG1245DP		18.7 ²		VG1245DP+906AGA	VG1245DP+906IGA	VG1245DP+906GGA
VG1245DR		29.2		VG1245DR+906AGA	VG1245DR+906IGA	VG1245DR+906GGA
VG1245EP	1-1/2	18.7 ²	200	VG1245EP+906AGA	VG1245EP+906IGA	VG1245EP+906GGA
VG1245ER		29.2 ²		VG1245ER+906AGA	VG1245ER+906IGA	VG1245ER+906GGA
VG1245ES		46.8		VG1245ES+906AGA	VG1245ES+906IGA	VG1245ES+906GGA
VG1245FR	2	29.2 ²	200	VG1245FR+909AGA	—	VG1245FR+909GGA
VG1245FS		48.8 ²		VG1245FS+909AGA	—	VG1245FS+909GGA
VG1245FT		73.7		VG1245FT+909AGA	—	VG1245FT+909GGA

1. To avoid excessive wear or drive time on the motor for the AGx models, use a controller or software that provides a timeout function to remove the signal at the end of rotation (stall).
2. Cv has a characterizing risk.

Table 7: Two-Way Stainless Steel Trim Ball Valves, Non-Spring Return M9106/M9109 Electric Actuators with Switches

Fluid Temperatures: -22 to 284°F (-30 to 140°C) Water and 15 psi Saturated Steam				AC 24 V		
				On/Off (Floating) without Timeout ¹	On/Off (Floating) with Timeout	DC 0 to 10 V Proportional
Valve	Size, in.	Cv	Closeoff psig	M9106-AGC-2 M9109-AGC-2	M9106-IGC-2	M9106-GGC-2 M9109-GGC-2
VG1245AD	1/2	1.2 ²	200	VG1245AD+906AGC	VG1245AD+906IGC	VG1245AD+906GGC
VG1245AE		1.9 ²		VG1245AE+906AGC	VG1245AE+906IGC	VG1245AE+906GGC
VG1245AF		2.9 ²		VG1245AF+906AGC	VG1245AF+906IGC	VG1245AF+906GGC
VG1245AG		4.7 ²		VG1245AG+906AGC	VG1245AG+906IGC	VG1245AG+906GGC
VG1245AL		7.4 ²		VG1245AL+906AGC	VG1245AL+906IGC	VG1245AL+906GGC
VG1245AN		11.7		VG1245AN+906AGC	VG1245AN+906IGC	VG1245AN+906GGC
VG1245BG	3/4	4.7 ²	200	VG1245BG+906AGC	VG1245BG+906IGC	VG1245BG+906GGC
VG1245BL		7.4 ²		VG1245BL+906AGC	VG1245BL+906IGC	VG1245BL+906GGC
VG1245BN		11.7		VG1245BN+906AGC	VG1245BN+906IGC	VG1245BN+906GGC
VG1245CL	1	7.4 ²	200	VG1245CL+906AGC	VG1245CL+906IGC	VG1245CL+906GGC
VG1245CN		11.7 ²		VG1245CN+906AGC	VG1245CN+906IGC	VG1245CN+906GGC
VG1245CP		18.7		VG1245CP+906AGC	VG1245CP+906IGC	VG1245CP+906GGC
VG1245DN	1-1/4	11.7 ²	200	VG1245DN+906AGC	VG1245DN+906IGC	VG1245DN+906GGC
VG1245DP		18.7 ²		VG1245DP+906AGC	VG1245DP+906IGC	VG1245DP+906GGC
VG1245DR		29.2		VG1245DR+906AGC	VG1245DR+906IGC	VG1245DR+906GGC
VG1245EP	1-1/2	18.7 ²	200	VG1245EP+906AGC	VG1245EP+906IGC	VG1245EP+906GGC
VG1245ER		29.2 ²		VG1245ER+906AGC	VG1245ER+906IGC	VG1245ER+906GGC
VG1245ES		46.8		VG1245ES+906AGC	VG1245ES+906IGC	VG1245ES+906GGC
VG1245FR	2	29.2 ²	200	VG1245FR+909AGC	—	VG1245FR+909GGC
VG1245FS		46.8 ²		VG1245FS+909AGC	—	VG1245FS+909GGC
VG1245FT		73.7		VG1245FT+909AGC	—	VG1245FT+909GGC

1. To avoid excessive wear or drive time on the motor for the AGx models, use a controller or software that provides a timeout function to remove the signal at the end of rotation (stall).

2. Cv has a characterizing disk.

Table 8: Two-Way Stainless Steel Trim Ball Valves, Spring Return Valve Open - Valve Normally Open, VA9203/VA9208 Actuators with Switches (Not Rated for Steam Service)

Fluid Temperatures: -22 to 212°F (-30 to 100°C) Not Rated for Steam Service				AC 24 V			AC 85–264 V (VA9203) AC 120 V (VA9208)
				Floating	DC 0 to 10 V Proportional	On/Off	On/Off
Valve	Size, in.	Cv	Closeoff psig	Spring Return Open —	Valve Normally Open —	Actuators with One Switch	
				VA9203-AGB-2Z	VA9203-GGB-2Z	VA9203-BGB-2	VA9203-BUB-2
VG1245AD	1/2	1.2 ¹	200	VG1245AD+923AGB	VG1245AD+923GGB	VG1245AD+923BGB	VG1245AD+923BUB
VG1245AE		1.9 ¹		VG1245AE+923AGB	VG1245AE+923GGB	VG1245AE+923BGB	VG1245AE+923BUB
VG1245AF		2.9 ¹		VG1245AF+923AGB	VG1245AF+923GGB	VG1245AF+923BGB	VG1245AF+923BUB
VG1245AG		4.7 ¹		VG1245AG+923AGB	VG1245AG+923GGB	VG1245AG+923BGB	VG1245AG+923BUB
VG1245AL		7.4 ¹		VG1245AL+923AGB	VG1245AL+923GGB	VG1245AL+923BGB	VG1245AL+923BUB
VG1245AN		11.7		VG1245AN+923AGB	VG1245AN+923GGB	VG1245AN+923BGB	VG1245AN+923BUB
VG1245BG	3/4	4.7 ¹	200	VG1245BG+923AGB	VG1245BG+923GGB	VG1245BG+923BGB	VG1245BG+923BUB
VG1245BL		7.4 ¹		VG1245BL+923AGB	VG1245BL+923GGB	VG1245BL+923BGB	VG1245BL+923BUB
VG1245BN		11.7		VG1245BN+923AGB	VG1245BN+923GGB	VG1245BN+923BGB	VG1245BN+923BUB
VG1245CL	1	7.4 ¹	200	VG1245CL+923AGB	VG1245CL+923GGB	VG1245CL+923BGB	VG1245CL+923BUB
VG1245CN		11.7 ¹		VG1245CN+923AGB	VG1245CN+923GGB	VG1245CN+923BGB	VG1245CN+923BUB
VG1245CP		18.7		VG1245CP+923AGB	VG1245CP+923GGB	VG1245CP+923BGB	VG1245CP+923BUB
Valve	Size, in.	Cv	Closeoff psig	Spring Return Open —	Valve Normally Open —	Actuators with Two Switches	
				VA9208-AGC-3	VA9208-GGC-3	VA9208-BGC-3	VA9208-BAC-3
VG1245DN	1-1/4	11.7 ¹	200	VG1245DN+938AGC	VG1245DN+938GGC	VG1245DN+938BGC	VG1245DN+938BAC
VG1245DP		18.7 ¹		VG1245DP+938AGC	VG1245DP+938GGC	VG1245DP+938BGC	VG1245DP+938BAC
VG1245DR		29.2		VG1245DR+938AGC	VG1245DR+938GGC	VG1245DR+938BGC	VG1245DR+938BAC
VG1245EP	1-1/2	18.7 ¹	200	VG1245EP+938AGC	VG1245EP+938GGC	VG1245EP+938BGC	VG1245EP+938BAC
VG1245ER		29.2 ¹		VG1245ER+938AGC	VG1245ER+938GGC	VG1245ER+938BGC	VG1245ER+938BAC
VG1245ES		46.8		VG1245ES+938AGC	VG1245ES+938GGC	VG1245ES+938BGC	VG1245ES+938BAC
VG1245FR	2	29.2 ¹	200	VG1245FR+938AGC	VG1245FR+938GGC	VG1245FR+938BGC	VG1245FR+938BAC
VG1245FS		46.8 ¹		VG1245FS+938AGC	VG1245FS+938GGC	VG1245FS+938BGC	VG1245FS+938BAC
VG1245FT		73.7		VG1245FT+938AGC	VG1245FT+938GGC	VG1245FT+938BGC	VG1245FT+938BAC

1. Cv has a characterizing disk.

Table 9: Two-Way Stainless Steel Trim Ball Valves, Spring Return Valve Closed - Valve Normally Closed, VA9203/VA9208 Actuators with Switches (Not Rated for Steam Service)

Fluid Temperatures: -22 to 212°F (-30 to 100°C) Not Rated for Steam Service				AC 24 V			AC 85–264 V (VA9203) AC 120 V (VA9208)
				Floating	DC 0 to 10 V Proportional	On/Off	On/Off
Valve	Size, in.	Cv	Closeoff psig	Spring Return Closed — Valve Normally Closed — Actuators with One Switch			
				VA9203-AGB-2Z	VA9203-GGB-2Z	VA9203-BGB-2	VA9203-BUB-2
VG1245AD	1/2	1.2 ¹	200	VG1245AD+943AGB	VG1245AD+943GGB	VG1245AD+943BGB	VG1245AD+943BUB
VG1245AE		1.9 ¹		VG1245AE+943AGB	VG1245AE+943GGB	VG1245AE+943BGB	VG1245AE+943BUB
VG1245AF		2.9 ¹		VG1245AF+943AGB	VG1245AF+943GGB	VG1245AF+943BGB	VG1245AF+943BUB
VG1245AG		4.7 ¹		VG1245AG+943AGB	VG1245AG+943GGB	VG1245AG+943BGB	VG1245AG+943BUB
VG1245AL		7.4 ¹		VG1245AL+943AGB	VG1245AL+943GGB	VG1245AL+943BGB	VG1245AL+943BUB
VG1245AN		11.7		VG1245AN+943AGB	VG1245AN+943GGB	VG1245AN+943BGB	VG1245AN+943BUB
VG1245BG	3/4	4.7 ¹	200	VG1245BG+943AGB	VG1245BG+943GGB	VG1245BG+943BGB	VG1245BG+943BUB
VG1245BL		7.4 ¹		VG1245BL+943AGB	VG1245BL+943GGB	VG1245BL+943BGB	VG1245BL+943BUB
VG1245BN		11.7		VG1245BN+943AGB	VG1245BN+943GGB	VG1245BN+943BGB	VG1245BN+943BUB
VG1245CL	1	7.4 ¹	200	VG1245CL+943AGB	VG1245CL+943GGB	VG1245CL+943BGB	VG1245CL+943BUB
VG1245CN		11.7 ¹		VG1245CN+943AGB	VG1245CN+943GGB	VG1245CN+943BGB	VG1245CN+943BUB
VG1245CP		18.7		VG1245CP+943AGB	VG1245CP+943GGB	VG1245CP+943BGB	VG1245CP+943BUB
Valve	Size, in.	Cv	Closeoff psig	Spring Return Closed — Valve Normally Closed — Actuators with Two Switches			
				VA9208-AGC-3	VA9208-GGC-3	VA9208-BGC-3	VA9208-BAC-3
VG1245DN	1-1/4	11.7 ¹	200	VG1245DN+958AGC	VG1245DN+958GGC	VG1245DN+958BGC	VG1245DN+958BAC
VG1245DP		18.7 ¹		VG1245DP+958AGC	VG1245DP+958GGC	VG1245DP+958BGC	VG1245DP+958BAC
VG1245DR		29.2		VG1245DR+958AGC	VG1245DR+958GGC	VG1245DR+958BGC	VG1245DR+958BAC
VG1245EP	1-1/2	18.7 ¹	200	VG1245EP+958AGC	VG1245EP+958GGC	VG1245EP+958BGC	VG1245EP+958BAC
VG1245ER		29.2 ¹		VG1245ER+958AGC	VG1245ER+958GGC	VG1245ER+958BGC	VG1245ER+958BAC
VG1245ES		46.8		VG1245ES+958AGC	VG1245ES+958GGC	VG1245ES+958BGC	VG1245ES+958BAC
VG1245FR	2	29.2 ¹	200	VG1245FR+958AGC	VG1245FR+958GGC	VG1245FR+958BGC	VG1245FR+958BAC
VG1245FS		46.8 ¹		VG1245FS+958AGC	VG1245FS+958GGC	VG1245FS+958BGC	VG1245FS+958BAC
VG1245FT		73.7		VG1245FT+958AGC	VG1245FT+958GGC	VG1245FT+958BGC	VG1245FT+958BAC

1. Cv has a characterizing disk.

Table 10: Two-Way Stainless Steel Trim Ball Valves, Spring Return Valve Open - Valve Normally Open, VA9203/VA9208 Actuators with Switches and Optional M9000-561 Thermal Barrier

Fluid Temperatures: -22 to 284°F (-30 to 140°C) Water and 15 psi Steam				AC 24 V			AC 85–264 V (VA9203) AC 120 V (VA9208)
				Floating	DC 0 to 10 V Proportional	On/Off	On/Off
Valve	Size, in.	Cv	Closeoff psig	Spring Return Open — Valve Normally Open — Actuators with One Switch			
				VA9203-AGB-2Z	VA9203-GGB-2Z	VA9203-BGB-2	VA9203-BUB-2
VG1245AD	1/2	1.2 ¹	200	VG1245ADH923AGB	VG1245ADH923GGB	VG1245ADH923BGB	VG1245ADH923BUB
VG1245AE		1.9 ¹		VG1245AEH923AGB	VG1245AEH923GGB	VG1245AEH923BGB	VG1245AEH923BUB
VG1245AF		2.9 ¹		VG1245AFH923AGB	VG1245AFH923GGB	VG1245AFH923BGB	VG1245AFH923BUB
VG1245AG		4.7 ¹		VG1245AGH923AGB	VG1245AGH923GGB	VG1245AGH923BGB	VG1245AGH923BUB
VG1245AL		7.4 ¹		VG1245ALH923AGB	VG1245ALH923GGB	VG1245ALH923BGB	VG1245ALH923BUB
VG1245AN		11.7		VG1245ANH923AGB	VG1245ANH923GGB	VG1245ANH923BGB	VG1245ANH923BUB
VG1245BG	3/4	4.7 ¹	200	VG1245BGH923AGB	VG1245BGH923GGB	VG1245BGH923BGB	VG1245BGH923BUB
VG1245BL		7.4 ¹		VG1245BLH923AGB	VG1245BLH923GGB	VG1245BLH923BGB	VG1245BLH923BUB
VG1245BN		11.7		VG1245BNH923AGB	VG1245BNH923GGB	VG1245BNH923BGB	VG1245BNH923BUB
VG1245CL	1	7.4 ¹	200	VG1245CLH923AGB	VG1245CLH923GGB	VG1245CLH923BGB	VG1245CLH923BUB
VG1245CN		11.7 ¹		VG1245CNH923AGB	VG1245CNH923GGB	VG1245CNH923BGB	VG1245CNH923BUB
VG1245CP		18.7		VG1245CPH923AGB	VG1245CPH923GGB	VG1245CPH923BGB	VG1245CPH923BUB
Valve	Size, in.	Cv	Closeoff psig	Spring Return Open — Valve Normally Open — Actuators with Two Switches			
				VA9208-AGC-3	VA9208-GGC-3	VA9208-BGC-3	VA9208-BAC-3
VG1245DN	1-1/4	11.7 ¹	200	VG1245DNH938AGC	VG1245DNH938GGC	VG1245DNH938BGC	VG1245DNH938BAC
VG1245DP		18.7 ¹		VG1245DPH938AGC	VG1245DPH938GGC	VG1245DPH938BGC	VG1245DPH938BAC
VG1245DR		29.2		VG1245DRH938AGC	VG1245DRH938GGC	VG1245DRH938BGC	VG1245DRH938BAC
VG1245EP	1-1/2	18.7 ¹	200	VG1245EPH938AGC	VG1245EPH938GGC	VG1245EPH938BGC	VG1245EPH938BAC
VG1245ER		29.2 ¹		VG1245ERH938AGC	VG1245ERH938GGC	VG1245ERH938BGC	VG1245ERH938BAC
VG1245ES		46.8		VG1245ESH938AGC	VG1245ESH938GGC	VG1245ESH938BGC	VG1245ESH938BAC
VG1245FR	2	29.2 ¹	200	VG1245FRH938AGC	VG1245FRH938GGC	VG1245FRH938BGC	VG1245FRH938BAC
VG1245FS		46.8 ¹		VG1245FSH938AGC	VG1245FSH938GGC	VG1245FSH938BGC	VG1245FSH938BAC
VG1245FT		73.7		VG1245FTH938AGC	VG1245FTH938GGC	VG1245FTH938BGC	VG1245FTH938BAC

1. Cv has a characterizing disk.

Table 11: Two-Way Stainless Steel Trim Ball Valves, Spring Return Valve Closed - Valve Normally Closed, VA9203/VA9208 Actuators with Switches and Optional M9000-561 Thermal Barrier

Fluid Temperatures: -22 to 284°F (-30 to 140°C) Water and 15 psi Steam				AC 24 V			AC 85–264 V (VA9203) AC 120 V (VA9208)
				Floating	DC 0 to 10 V Proportional	On/Off	On/Off
Valve	Size, in.	Cv	Closeoff psig	Spring Return Closed — Valve Normally Closed — Actuators with One Switch			
				VA9203-AGB-2Z	VA9203-GGB-2Z	VA9203-BGB-2	VA9203-BUB-2
VG1245AD	1/2	1.2 ¹	200	VG1245ADH943AGB	VG1245ADH943GGB	VG1245ADH943BGB	VG1245ADH943BUB
VG1245AE		1.9 ¹		VG1245AEH943AGB	VG1245AEH943GGB	VG1245AEH943BGB	VG1245AEH943BUB
VG1245AF		2.9 ¹		VG1245AFH943AGB	VG1245AFH943GGB	VG1245AFH943BGB	VG1245AFH943BUB
VG1245AG		4.7 ¹		VG1245AGH943AGB	VG1245AGH943GGB	VG1245AGH943BGB	VG1245AGH943BUB
VG1245AL		7.4 ¹		VG1245ALH943AGB	VG1245ALH943GGB	VG1245ALH943BGB	VG1245ALH943BUB
VG1245AN		11.7		VG1245ANH943AGB	VG1245ANH943GGB	VG1245ANH943BGB	VG1245ANH943BUB
VG1245BG	3/4	4.7 ¹	200	VG1245BGH943AGB	VG1245BGH943GGB	VG1245BGH943BGB	VG1245BGH943BUB
VG1245BL		7.4 ¹		VG1245BLH943AGB	VG1245BLH943GGB	VG1245BLH943BGB	VG1245BLH943BUB
VG1245BN		11.7		VG1245BNH943AGB	VG1245BNH943GGB	VG1245BNH943BGB	VG1245BNH943BUB
VG1245CL	1	7.4 ¹	200	VG1245CLH943AGB	VG1245CLH943GGB	VG1245CLH943BGB	VG1245CLH943BUB
VG1245CN		11.7 ¹		VG1245CNH943AGB	VG1245CNH943GGB	VG1245CNH943BGB	VG1245CNH943BUB
VG1245CP		18.7		VG1245CPH943AGB	VG1245CPH943GGB	VG1245CPH943BGB	VG1245CPH943BUB
Valve	Size, in.	Cv	Closeoff psig	Spring Return Closed — Valve Normally Closed — Actuators with Two Switches			
				VA9208-AGC-3	VA9208-GGC-3	VA9208-BGC-3	VA9208-BAC-3
VG1245DN	1-1/4	11.7 ¹	200	VG1245DNH958AGC	VG1245DNH958GGC	VG1245DNH958BGC	VG1245DNH958BAC
VG1245DP		18.7 ¹		VG1245DPH958AGC	VG1245DPH958GGC	VG1245DPH958BGC	VG1245DPH958BAC
VG1245DR		29.2		VG1245DRH958AGC	VG1245DRH958GGC	VG1245DRH958BGC	VG1245DRH958BAC
VG1245EP	1-1/2	18.7 ¹	200	VG1245EPH958AGC	VG1245EPH958GGC	VG1245EPH958BGC	VG1245EPH958BAC
VG1245ER		29.2 ¹		VG1245ERH958AGC	VG1245ERH958GGC	VG1245ERH958BGC	VG1245ERH958BAC
VG1245ES		46.8		VG1245ESH958AGC	VG1245ESH958GGC	VG1245ESH958BGC	VG1245ESH958BAC
VG1245FR	2	29.2 ¹	200	VG1245FRH958AGC	VG1245FRH958GGC	VG1245FRH958BGC	VG1245FRH958BAC
VG1245FS		46.8 ¹		VG1245FSH958AGC	VG1245FSH958GGC	VG1245FSH958BGC	VG1245FSH958BAC
VG1245FT		73.7		VG1245FTH958AGC	VG1245FTH958GGC	VG1245FTH958BGC	VG1245FTH958BAC

1. Cv has a characterizing disk.

Table 12: Two-Way Stainless Steel Trim Ball Valves, Spring Return Valve Open - Valve Normally Open, VA9203/VA9208 Actuators without Switches (Not Rated for Steam Service)

Fluid Temperatures: -22 to 212°F (-30 to 100°C) Not Rated for Steam Service				AC 24 V			AC 85–264 V (VA9203) AC 120 V (VA9208)
				Floating	DC 0 to 10 V Proportional	On/Off	On/Off
Valve	Size, in.	Cv	Closeoff psig	Spring Return Open — Valve Normally Open — Actuators without Switches			
				VA9203-AGA-2Z	VA9203-GGA-2Z	VA9203-BGA-2	VA9203-BUA-2
VG1245AD	1/2	1.2 ¹	200	VG1245AD+923AGA	VG1245AD+923GGA	VG1245AD+923BGA	VG1245AD+923BUA
VG1245AE		1.9 ¹		VG1245AE+923AGA	VG1245AE+923GGA	VG1245AE+923BGA	VG1245AE+923BUA
VG1245AF		2.9 ¹		VG1245AF+923AGA	VG1245AF+923GGA	VG1245AF+923BGA	VG1245AF+923BUA
VG1245AG		4.7 ¹		VG1245AG+923AGA	VG1245AG+923GGA	VG1245AG+923BGA	VG1245AG+923BUA
VG1245AL		7.4 ¹		VG1245AL+923AGA	VG1245AL+923GGA	VG1245AL+923BGA	VG1245AL+923BUA
VG1245AN		11.7		VG1245AN+923AGA	VG1245AN+923GGA	VG1245AN+923BGA	VG1245AN+923BUA
VG1245BG	3/4	4.7 ¹	200	VG1245BG+923AGA	VG1245BG+923GGA	VG1245BG+923BGA	VG1245BG+923BUA
VG1245BL		7.4 ¹		VG1245BL+923AGA	VG1245BL+923GGA	VG1245BL+923BGA	VG1245BL+923BUA
VG1245BN		11.7		VG1245BN+923AGA	VG1245BN+923GGA	VG1245BN+923BGA	VG1245BN+923BUA
VG1245CL	1	7.4 ¹	200	VG1245CL+923AGA	VG1245CL+923GGA	VG1245CL+923BGA	VG1245CL+923BUA
VG1245CN		11.7 ¹		VG1245CN+923AGA	VG1245CN+923GGA	VG1245CN+923BGA	VG1245CN+923BUA
VG1245CP		18.7		VG1245CP+923AGA	VG1245CP+923GGA	VG1245CP+923BGA	VG1245CP+923BUA
Valve	Size, in.	Cv	Closeoff psig	Spring Return Open — Valve Normally Open — Actuators without Switches			
				VA9208-AGA-2	VA9208-GGA-2	VA9208-BGA-3	VA9208-BAA-3
VG1245DN	1-1/4	11.7 ¹	200	VG1245DN+928AGA	VG1245DN+928GGA	VG1245DN+938BGA	VG1245DN+938BAA
VG1245DP		18.7 ¹		VG1245DP+928AGA	VG1245DP+928GGA	VG1245DP+938BGA	VG1245DP+938BAA
VG1245DR		29.2		VG1245DR+928AGA	VG1245DR+928GGA	VG1245DR+938BGA	VG1245DR+938BAA
VG1245EP	1-1/2	18.7 ¹	200	VG1245EP+928AGA	VG1245EP+928GGA	VG1245EP+938BGA	VG1245EP+938BAA
VG1245ER		29.2 ¹		VG1245ER+928AGA	VG1245ER+928GGA	VG1245ER+938BGA	VG1245ER+938BAA
VG1245ES		46.8		VG1245ES+928AGA	VG1245ES+928GGA	VG1245ES+938BGA	VG1245ES+938BAA
VG1245FR	2	29.2 ¹	200	VG1245FR+928AGA	VG1245FR+928GGA	VG1245FR+938BGA	VG1245FR+938BAA
VG1245FS		46.8 ¹		VG1245FS+928AGA	VG1245FS+928GGA	VG1245FS+938BGA	VG1245FS+938BAA
VG1245FT		73.7		VG1245FT+928AGA	VG1245FT+928GGA	VG1245FT+938BGA	VG1245FT+938BAA

1. Cv has a characterizing disk.

Table 13: Two-Way Stainless Steel Trim Ball Valves, Spring Return Valve Closed - Valve Normally Closed, VA9203/VA9208 Actuators without Switches (Not Rated for Steam Service)

Fluid Temperatures: -22 to 212°F (-30 to 100°C) Not Rated for Steam Service				AC 24 V			AC 85–264 V (VA9203) AC 120 V (VA9208)
				Floating	DC 0 to 10 V Proportional	On/Off	On/Off
Valve	Size, in.	Cv	Closeoff psig	Spring Return Closed — Valve Normally Closed — Actuators without Switches			
				VA9203-AGA-2Z	VA9203-GGA-2Z	VA9203-BGA-2	VA9203-BUA-2
VG1245AD	1/2	1.2 ¹	200	VG1245AD+943AGA	VG1245AD+943GGA	VG1245AD+943BGA	VG1245AD+943BUA
VG1245AE		1.9 ¹		VG1245AE+943AGA	VG1245AE+943GGA	VG1245AE+943BGA	VG1245AE+943BUA
VG1245AF		2.9 ¹		VG1245AF+943AGA	VG1245AF+943GGA	VG1245AF+943BGA	VG1245AF+943BUA
VG1245AG		4.7 ¹		VG1245AG+943AGA	VG1245AG+943GGA	VG1245AG+943BGA	VG1245AG+943BUA
VG1245AL		7.4 ¹		VG1245AL+943AGA	VG1245AL+943GGA	VG1245AL+943BGA	VG1245AL+943BUA
VG1245AN		11.7		VG1245AN+943AGA	VG1245AN+943GGA	VG1245AN+943BGA	VG1245AN+943BUA
VG1245BG	3/4	4.7 ¹	200	VG1245BG+943AGA	VG1245BG+943GGA	VG1245BG+943BGA	VG1245BG+943BUA
VG1245BL		7.4 ¹		VG1245BL+943AGA	VG1245BL+943GGA	VG1245BL+943BGA	VG1245BL+943BUA
VG1245BN		11.7		VG1245BN+943AGA	VG1245BN+943GGA	VG1245BN+943BGA	VG1245BN+943BUA
VG1245CL	1	7.4 ¹	200	VG1245CL+943AGA	VG1245CL+943GGA	VG1245CL+943BGA	VG1245CL+943BUA
VG1245CN		11.7 ¹		VG1245CN+943AGA	VG1245CN+943GGA	VG1245CN+943BGA	VG1245CN+943BUA
VG1245CP		18.7		VG1245CP+943AGA	VG1245CP+943GGA	VG1245CP+943BGA	VG1245CP+943BUA
Valve	Size, in.	Cv	Closeoff psig	Spring Return Closed — Valve Normally Closed — Actuators without Switches			
				VA9208-AGA-2	VA9208-GGA-2	VA9208-BGA-3	VA9208-BAA-3
VG1245DN	1-1/4	11.7 ¹	200	VG1245DN+948AGA	VG1245DN+948GGA	VG1245DN+958BGA	VG1245DN+958BAA
VG1245DP		18.7 ¹		VG1245DP+948AGA	VG1245DP+948GGA	VG1245DP+958BGA	VG1245DP+958BAA
VG1245DR		29.2		VG1245DR+948AGA	VG1245DR+948GGA	VG1245DR+958BGA	VG1245DR+958BAA
VG1245EP	1-1/2	18.7 ¹	200	VG1245EP+948AGA	VG1245EP+948GGA	VG1245EP+958BGA	VG1245EP+958BAA
VG1245ER		29.2 ¹		VG1245ER+948AGA	VG1245ER+948GGA	VG1245ER+958BGA	VG1245ER+958BAA
VG1245ES		46.8		VG1245ES+948AGA	VG1245ES+948GGA	VG1245ES+958BGA	VG1245ES+958BAA
VG1245FR	2	29.2 ¹	200	VG1245FR+948AGA	VG1245FR+948GGA	VG1245FR+958BGA	VG1245FR+958BAA
VG1245FS		46.8 ¹		VG1245FS+948AGA	VG1245FS+948GGA	VG1245FS+958BGA	VG1245FS+958BAA
VG1245FT		73.7		VG1245FT+948AGA	VG1245FT+948GGA	VG1245FT+958BGA	VG1245FT+958BAA

1. Cv has characterizing disk.

Table 14: Two-Way Stainless Steel Trim Ball Valves, Spring Return Valve Open - Valve Normally Open, VA9203/VA9208 Actuators without Switches with Optional M9000-561 Thermal Barrier

Fluid Temperatures: -22 to 284°F (-30 to 140°C) Water and 15 psi Saturated Steam				AC 24 V			AC 85–264 V (VA9203) AC 120 V (VA9208)
				Floating	DC 0 to 10 V Proportional	On/Off	On/Off
Valve	Size, in.	Cv	Closeoff psig	Spring Return Open — Valve Normally Open — Actuators without Switches			
				VA9203-AGA-2Z	VA9203-GGA-2Z	VA9203-BGA-2	VA9203-BUA-2
VG1245AD	1/2	1.2 ¹	200	VG1245ADH923AGA	VG1245ADH923GGA	VG1245ADH923BGA	VG1245ADH923BUA
VG1245AE		1.9 ¹		VG1245AEH923AGA	VG1245AEH923GGA	VG1245AEH923BGA	VG1245AEH923BUA
VG1245AF		2.9 ¹		VG1245AFH923AGA	VG1245AFH923GGA	VG1245AFH923BGA	VG1245AFH923BUA
VG1245AG		4.7 ¹		VG1245AGH923AGA	VG1245AGH923GGA	VG1245AGH923BGA	VG1245AGH923BUA
VG1245AL		7.4 ¹		VG1245ALH923AGA	VG1245ALH923GGA	VG1245ALH923BGA	VG1245ALH923BUA
VG1245AN		11.7		VG1245ANH923AGA	VG1245ANH923GGA	VG1245ANH923BGA	VG1245ANH923BUA
VG1245BG	3/4	4.7 ¹	200	VG1245BGH923AGA	VG1245BGH923GGA	VG1245BGH923BGA	VG1245BGH923BUA
VG1245BL		7.4 ¹		VG1245BLH923AGA	VG1245BLH923GGA	VG1245BLH923BGA	VG1245BLH923BUA
VG1245BN		11.7		VG1245BNH923AGA	VG1245BNH923GGA	VG1245BNH923BGA	VG1245BNH923BUA
VG1245CL	1	7.4 ¹	200	VG1245CLH923AGA	VG1245CLH923GGA	VG1245CLH923BGA	VG1245CLH923BUA
VG1245CN		11.7 ¹		VG1245CNH923AGA	VG1245CNH923GGA	VG1245CNH923BGA	VG1245CNH923BUA
VG1245CP		18.7		VG1245CPH923AGA	VG1245CPH923GGA	VG1245CPH923BGA	VG1245CPH923BUA
Valve	Size, in.	Cv	Closeoff psig	Spring Return Open — Valve Normally Open — Actuators without Switches			
				VA9208-AGA-2	VA9208-GGA-2	VA9208-BGA-3	VA9208-BAA-3
VG1245DN	1-1/4	11.7 ¹	200	VG1245DNH928AGA	VG1245DNH928GGA	VG1245DNH938BGA	VG1245DNH938BAA
VG1245DP		18.7 ¹		VG1245DPH928AGA	VG1245DPH928GGA	VG1245DPH938BGA	VG1245DPH938BAA
VG1245DR		29.2		VG1245DRH928AGA	VG1245DRH928GGA	VG1245DRH938BGA	VG1245DRH938BAA
VG1245EP	1-1/2	18.7 ¹	200	VG1245EPH928AGA	VG1245EPH928GGA	VG1245EPH938BGA	VG1245EPH938BAA
VG1245ER		29.2 ¹		VG1245ERH928AGA	VG1245ERH928GGA	VG1245ERH938BGA	VG1245ERH938BAA
VG1245ES		46.8		VG1245ESH928AGA	VG1245ESH928GGA	VG1245ESH938BGA	VG1245ESH938BAA
VG1245FR	2	29.2 ¹	200	VG1245FRH928AGA	VG1245FRH928GGA	VG1245FRH938BGA	VG1245FRH938BAA
VG1245FS		46.8 ¹		VG1245FSH928AGA	VG1245FSH928GGA	VG1245FSH938BGA	VG1245FSH938BAA
VG1245FT		73.7		VG1245FTH928AGA	VG1245FTH928GGA	VG1245FTH938BGA	VG1245FTH938BAA

1. Cv has a characterizing disk.

Table 15: Two-Way Stainless Steel Trim Ball Valves, Spring Return Valve Closed - Valve Normally Closed, VA9203/VA9208 Actuators without Switches with Optional M9000-561 Thermal Barrier

Fluid Temperatures: -22 to 284°F (-30 to 140°C) Water and 15 psi Saturated Steam				AC 24 V			AC 85–264 V (VA9203) AC 120 V (VA9208)
				Floating	DC 0 to 10 V Proportional	On/Off	On/Off
Valve	Size, in.	Cv	Closeoff psig	Spring Return Closed — Valve Normally Closed — Actuators without Switches			
				VA9203-AGA-2Z	VA9203-GGA-2Z	VA9203-BGA-2	VA9203-BUA-2
VG1245AD	1/2	1.2 ¹	200	VG1245ADH943AGA	VG1245ADH943GGA	VG1245ADH943BGA	VG1245ADH943BUA
VG1245AE		1.9 ¹		VG1245AEH943AGA	VG1245AEH943GGA	VG1245AEH943BGA	VG1245AEH943BUA
VG1245AF		2.9 ¹		VG1245AFH943AGA	VG1245AFH943GGA	VG1245AFH943BGA	VG1245AFH943BUA
VG1245AG		4.7 ¹		VG1245AGH943AGA	VG1245AGH943GGA	VG1245AGH943BGA	VG1245AGH943BUA
VG1245AL		7.4 ¹		VG1245ALH943AGA	VG1245ALH943GGA	VG1245ALH943BGA	VG1245ALH943BUA
VG1245AN		11.7		VG1245ANH943AGA	VG1245ANH943GGA	VG1245ANH943BGA	VG1245ANH943BUA
VG1245BG	3/4	4.7 ¹	200	VG1245BGH943AGA	VG1245BGH943GGA	VG1245BGH943BGA	VG1245BGH943BUA
VG1245BL		7.4 ¹		VG1245BLH943AGA	VG1245BLH943GGA	VG1245BLH943BGA	VG1245BLH943BUA
VG1245BN		11.7		VG1245BNH943AGA	VG1245BNH943GGA	VG1245BNH943BGA	VG1245BNH943BUA
VG1245CL	1	7.4 ¹	200	VG1245CLH943AGA	VG1245CLH943GGA	VG1245CLH943BGA	VG1245CLH943BUA
VG1245CN		11.7 ¹		VG1245CNH943AGA	VG1245CNH943GGA	VG1245CNH943BGA	VG1245CNH943BUA
VG1245CP		18.7		VG1245CPH943AGA	VG1245CPH943GGA	VG1245CPH943BGA	VG1245CPH943BUA
Valve	Size, in.	Cv	Closeoff psig	Spring Return Closed — Valve Normally Closed — Actuators without Switches			
				VA9208-AGA-2	VA9208-GGA-2	VA9208-BGA-3	VA9208-BAA-3
VG1245DN	1-1/4	11.7 ¹	200	VG1245DNH948AGA	VG1245DNH948GGA	VG1245DNH958BGA	VG1245DNH958BAA
VG1245DP		18.7 ¹		VG1245DPH948AGA	VG1245DPH948GGA	VG1245DPH958BGA	VG1245DPH958BAA
VG1245DR		29.2		VG1245DRH948AGA	VG1245DRH948GGA	VG1245DRH958BGA	VG1245DRH958BAA
VG1245EP	1-1/2	18.7 ¹	200	VG1245EPH948AGA	VG1245EPH948GGA	VG1245EPH958BGA	VG1245EPH958BAA
VG1245ER		29.2 ¹		VG1245ERH948AGA	VG1245ERH948GGA	VG1245ERH958BGA	VG1245ERH958BAA
VG1245ES		46.8		VG1245ESH948AGA	VG1245ESH948GGA	VG1245ESH958BGA	VG1245ESH958BAA
VG1245FR	2	29.2 ¹	200	VG1245FRH948AGA	VG1245FRH948GGA	VG1245FRH958BGA	VG1245FRH958BAA
VG1245FS		46.8 ¹		VG1245FSH948AGA	VG1245FSH948GGA	VG1245FSH958BGA	VG1245FSH958BAA
VG1245FT		73.7		VG1245FTH948AGA	VG1245FTH948GGA	VG1245FTH958BGA	VG1245FTH958BAA

1. Cv has characterizing disk.

Table 16: Three-Way Stainless Steel Trim Ball Valves, Non-Spring Return, VA9104 Electric Actuators without Switches

Fluid Temperatures: -4 to 212°F (-22 to 100°C) Not Rated for Steam Service				AC 24 V		
				On/Off (Floating) without Timeout ¹	On/Off (Floating) with Timeout	DC 0 to 10 V Proportional
Valve	Size, in.	Cv (Port A/B)	Closeoff psig	Actuators with M3 Screw Terminals		
				VA9104-AGA-3S	VA9104-IGA-3S	VA9104-GGA-3S
VG1845AD	1/2	1.2/0.7 ²	200	VG1845AD+9T4AGA	VG1845AD+9T4IGA	VG1845AD+9T4GGA
VG1845AE		1.9/1.2 ²		VG1845AE+9T4AGA	VG1845AE+9T4IGA	VG1845AE+9T4GGA
VG1845AF		2.9/1.9 ²		VG1845AF+9T4AGA	VG1845AF+9T4IGA	VG1845AF+9T4GGA
VG1845AG		4.7/2.9 ²		VG1845AG+9T4AGA	VG1845AG+9T4IGA	VG1845AG+9T4GGA
VG1845AL		7.4/4.7 ²		VG1845AL+9T4AGA	VG1845AL+9T4IGA	VG1845AL+9T4GGA
VG1845AN		11.7/5.8		VG1845AN+9T4AGA	VG1845AN+9T4IGA	VG1845AN+9T4GGA
VG1845BG	3/4	4.7/2.9 ²	200	VG1845BG+9T4AGA	VG1845BG+9T4IGA	VG1845BG+9T4GGA
VG1845BL		7.4/4.7 ²		VG1845BL+9T4AGA	VG1845BL+9T4IGA	VG1845BL+9T4GGA
VG1845BN		11.7/5.8		VG1845BN+9T4AGA	VG1845BN+9T4IGA	VG1845BN+9T4GGA
VG1845CL	1	7.4/4.7 ²	200	VG1845CL+9T4AGA	VG1845CL+9T4IGA	VG1845CL+9T4GGA
VG1845CN		11.7/7.4 ²		VG1845CN+9T4AGA	VG1845CN+9T4IGA	VG1845CN+9T4GGA
VG1845CP		18.7/9.4		VG1845CP+9T4AGA	VG1845CP+9T4IGA	VG1845CP+9T4GGA
Valve	Size, in.	Cv (Port A/B)	Closeoff psig	Actuators with 120 in. (3.05 m) 18 AWG Plenum Cable		
				VA9104-AGA-2S	VA9104-IGA-2S	VA9104-GGA-2S
VG1845AD	1/2	1.2/0.7 ²	200	VG1845AD+9A4AGA	VG1845AD+9A4IGA	VG1845AD+9A4GGA
VG1845AE		1.9/1.2 ²		VG1845AE+9A4AGA	VG1845AE+9A4IGA	VG1845AE+9A4GGA
VG1845AF		2.9/1.9 ²		VG1845AF+9A4AGA	VG1845AF+9A4IGA	VG1845AF+9A4GGA
VG1845AG		4.7/2.9 ²		VG1845AG+9A4AGA	VG1845AG+9A4IGA	VG1845AG+9A4GGA
VG1845AL		7.4/4.7 ²		VG1845AL+9A4AGA	VG1845AL+9A4IGA	VG1845AL+9A4GGA
VG1845AN		11.7/5.8		VG1845AN+9A4AGA	VG1845AN+9A4IGA	VG1845AN+9A4GGA
VG1845BG	3/4	4.7/2.9 ²	200	VG1845BG+9A4AGA	VG1845BG+9A4IGA	VG1845BG+9A4GGA
VG1845BL		7.4/4.7 ²		VG1845BL+9A4AGA	VG1845BL+9A4IGA	VG1845BL+9A4GGA
VG1845BN		11.7/5.8		VG1845BN+9A4AGA	VG1845BN+9A4IGA	VG1845BN+9A4GGA
VG1845CL	1	7.4/4.7 ²	200	VG1845CL+9A4AGA	VG1845CL+9A4IGA	VG1845CL+9A4GGA
VG1845CN		11.7/7.4 ²		VG1845CN+9A4AGA	VG1845CN+9A4IGA	VG1845CN+9A4GGA
VG1845CP		18.7/9.4		VG1845CP+9A4AGA	VG1845CP+9A4IGA	VG1845CP+9A4GGA

1. To avoid excessive wear or drive time on the motor for the AGA models, use a controller or software that provides a timeout function to remove the signal at the end of rotation (stall).
2. Cv has a characterizing disk.

Table 17: Three-Way Stainless Steel Trim Ball Valves, Non-Spring Return, VA9104 Electric Actuators without Switches with M9000-561 Thermal Barrier Installed

Fluid Temperatures: -22 to 284°F (-30 to 140°C) Water and 15 psi Saturated Steam				AC 24 V		
				On/Off (Floating) without Timeout ¹	On/Off (Floating) with Timeout	0 to 10 VDC Proportional
Valve	Size, in.	Cv (Port A/B)	Closeoff psig	Actuators with M3 Screw Terminals with M9000-561 Thermal Barrier Installed		
				VA9104-AGA-3S	VA9104-IGA-3S	VA9104-GGA-3S
VG1845AD	1/2	1.2/0.7 ²	200	VG1845ADH9T4AGA	VG1845ADH9T4IGA	VG1845ADH9T4GGA
VG1845AE		1.9/1.2 ²		VG1845AEH9T4AGA	VG1845AEH9T4IGA	VG1845AEH9T4GGA
VG1845AF		2.9/1.9 ²		VG1845AFH9T4AGA	VG1845AFH9T4IGA	VG1845AFH9T4GGA
VG1845AG		4.7/2.9 ²		VG1845AGH9T4AGA	VG1845AGH9T4IGA	VG1845AGH9T4GGA
VG1845AL		7.4/4.7 ²		VG1845ALH9T4AGA	VG1845ALH9T4IGA	VG1845ALH9T4GGA
VG1845AN		11.7/5.8		VG1845ANH9T4AGA	VG1845ANH9T4IGA	VG1845ANH9T4GGA
VG1845BG	3/4	4.7/2.9 ²	200	VG1845BGH9T4AGA	VG1845BGH9T4IGA	VG1845BGH9T4GGA
VG1845BL		7.4/4.7 ²		VG1845BLH9T4AGA	VG1845BLH9T4IGA	VG1845BLH9T4GGA
VG1845BN		11.7/5.8		VG1845BNH9T4AGA	VG1845BNH9T4IGA	VG1845BNH9T4GGA
VG1845CL	1	7.4/4.7 ²	200	VG1845CLH9T4AGA	VG1845CLH9T4IGA	VG1845CLH9T4GGA
VG1845CN		11.7/7.4 ²		VG1845CNH9T4AGA	VG1845CNH9T4IGA	VG1845CNH9T4GGA
VG1845CP		18.7/9.4		VG1845CPH9T4AGA	VG1845CPH9T4IGA	VG1845CPH9T4GGA
Valve	Size, in.	Cv (Port A/B)	Closeoff psig	Actuators with 120 in. (3.05 m) 18 AWG Plenum Cable with M9000-561 Thermal Barrier Installed		
				VA9104-AGA-2S	VA9104-IGA-2S	VA9104-GGA-2S
VG1845AD	1/2	1.2/0.7 ²	200	VG1845ADH9A4AGA	VG1845ADH9A4IGA	VG1845ADH9A4GGA
VG1845AE		1.9/1.2 ²		VG1845AEH9A4AGA	VG1845AEH9A4IGA	VG1845AEH9A4GGA
VG1845AF		2.9/1.9 ²		VG1845AFH9A4AGA	VG1845AFH9A4IGA	VG1845AFH9A4GGA
VG1845AG		4.7/2.9 ²		VG1845AGH9A4AGA	VG1845AGH9A4IGA	VG1845AGH9A4GGA
VG1845AL		7.4/4.7 ²		VG1845ALH9A4AGA	VG1845ALH9A4IGA	VG1845ALH9A4GGA
VG1845AN		11.7/5.8		VG1845ANH9A4AGA	VG1845ANH9A4IGA	VG1845ANH9A4GGA
VG1845BG	3/4	4.7/2.9 ²	200	VG1845BGH9A4AGA	VG1845BGH9A4IGA	VG1845BGH9A4GGA
VG1845BL		7.4/4.7 ²		VG1845BLH9A4AGA	VG1845BLH9A4IGA	VG1845BLH9A4GGA
VG1845BN		11.7/5.8		VG1845BNH9A4AGA	VG1845BNH9A4IGA	VG1845BNH9A4GGA
VG1845CL	1	7.4/4.7 ²	200	VG1845CLH9A4AGA	VG1845CLH9A4IGA	VG1845CLH9A4GGA
VG1845CN		11.7/7.4 ²		VG1845CNH9A4AGA	VG1845CNH9A4IGA	VG1845CNH9A4GGA
VG1845CP		18.7/9.4		VG1845CPH9A4AGA	VG1845CPH9A4IGA	VG1845CPH9A4GGA

1. To avoid excessive wear or drive time on the motor for the AGA models, use a controller or software that provides a timeout function to remove the signal at the end of rotation (stall).
2. Cv has a characterizing disk.

Table 18: Three-Way Stainless Steel Trim Ball Valves, Non-Spring Return, M9106/M9109 Electric Actuators without Switches

Fluid Temperatures: -22 to 284°F (-30 to 140°C) Water and 15 psi Saturated Steam				AC 24 V		
Valve	Size, in.	Cv (Port A/B)	Closeoff psig	On/Off (Floating) without Timeout ¹	On/Off (Floating) with Timeout	DC 0 to 10 V Proportional
				M9106-AGA-2 M9109-AGA-2	M9106-IGA-2	M9106-GGA-2 M9109-GGA-2
VG1845AD	1/2	1.2/0.7 ²	200	VG1845AD+906AGA	VG1845AD+906IGA	VG1845AD+906GGA
VG1845AE		1.9/1.2 ²		VG1845AE+906AGA	VG1845AE+906IGA	VG1845AE+906GGA
VG1845AF		2.9/1.9 ²		VG1845AF+906AGA	VG1845AF+906IGA	VG1845AF+906GGA
VG1845AG		4.7/2.9 ²		VG1845AG+906AGA	VG1845AG+906IGA	VG1845AG+906GGA
VG1845AL		7.4/4.7 ²		VG1845AL+906AGA	VG1845AL+906IGA	VG1845AL+906GGA
VG1845AN		11.7/5.8		VG1845AN+906AGA	VG1845AN+906IGA	VG1845AN+906GGA
VG1845BG	3/4	4.7/2.9 ²	200	VG1845BG+906AGA	VG1845BG+906IGA	VG1845BG+906GGA
VG1845BL		7.4/4.7 ²		VG1845BL+906AGA	VG1845BL+906IGA	VG1845BL+906GGA
VG1845BN		11.7/5.8		VG1845BN+906AGA	VG1845BN+906IGA	VG1845BN+906GGA
VG1845CL	1	7.4/4.7 ²	200	VG1845CL+906AGA	VG1845CL+906IGA	VG1845CL+906GGA
VG1845CN		11.7/7.4 ²		VG1845CN+906AGA	VG1845CN+906IGA	VG1845CN+906GGA
VG1845CP		18.7/9.4		VG1845CP+906AGA	VG1845CP+906IGA	VG1845CP+906GGA
VG1845DN	1-1/4	11.7/7.4 ²	200	VG1845DN+906AGA	VG1845DN+906IGA	VG1845DN+906GGA
VG1845DP		18.7/11.7 ²		VG1845DP+906AGA	VG1845DP+906IGA	VG1845DP+906GGA
VG1845DR		29.2/14.6		VG1845DR+906AGA	VG1845DR+906IGA	VG1845DR+906GGA
VG1845EP	1-1/2	18.7/11.7 ²	200	VG1845EP+906AGA	VG1845EP+906IGA	VG1845EP+906GGA
VG1845ER		29.2/18.7 ²		VG1845ER+906AGA	VG1845ER+906IGA	VG1845ER+906GGA
VG1845ES		46.8/23.4		VG1845ES+906AGA	VG1845ES+906IGA	VG1845ES+906GGA
VG1845FR	2	29.2/18.7 ²	200	VG1845FR+909AGA	—	VG1845FR+909GGA
VG1845FS		46.8/29.2 ²		VG1845FS+909AGA	—	VG1845FS+909GGA
VG1845FT		73.7/36.8		VG1845FT+909AGA	—	VG1845FT+909GGA

1. To avoid excessive wear or drive time on the motor for the AGA models, use a controller or software that provides a timeout function to remove the signal at the end of rotation (stall).
2. Cv has a characterizing disk.

Table 19: Three-Way Stainless Steel Trim Ball Valves, Non-Spring Return, M9106/M9109 Electric Actuators with Switches

Fluid Temperatures: -22 to 284°F (-30 to 140°C) Water and 15 psi Saturated Steam				AC 24 V		
Valve	Size, in.	Cv (Port A/B)	Closeoff psig	On/Off (Floating) without Timeout ¹	On/Off (Floating) with Timeout	DC 0 to 10 V Proportional
				M9106-AGC-2 M9109-AGC-2	M9106-IGC-2	M9106-GGC-2 M9109-GGC-2
VG1845AD	1/2	1.2/0.7 ²	200	VG1845AD+906AGC	VG1845AD+906IGC	VG1845AD+906GGC
VG1845AE		1.9/1.2 ²		VG1845AE+906AGC	VG1845AE+906IGC	VG1845AE+906GGC
VG1845AF		2.9/1.9 ²		VG1845AF+906AGC	VG1845AF+906IGC	VG1845AF+906GGC
VG1845AG		4.7/2.9 ²		VG1845AG+906AGC	VG1845AG+906IGC	VG1845AG+906GGC
VG1845AL		7.4/4.7 ²		VG1845AL+906AGC	VG1845AL+906IGC	VG1845AL+906GGC
VG1845AN		11.7/5.8		VG1845AN+906AGC	VG1845AN+906IGC	VG1845AN+906GGC
VG1845BG	3/4	4.7/2.9 ²	200	VG1845BG+906AGC	VG1845BG+906IGC	VG1845BG+906GGC
VG1845BL		7.4/4.7 ²		VG1845BL+906AGC	VG1845BL+906IGC	VG1845BL+906GGC
VG1845BN		11.7/5.8		VG1845BN+906AGC	VG1845BN+906IGC	VG1845BN+906GGC
VG1845CL	1	7.4/4.7 ²	200	VG1845CL+906AGC	VG1845CL+906IGC	VG1845CL+906GGC
VG1845CN		11.7/7.4 ²		VG1845CN+906AGC	VG1845CN+906IGC	VG1845CN+906GGC
VG1845CP		18.7/9.4		VG1845CP+906AGC	VG1845CP+906IGC	VG1845CP+906GGC
VG1845DN	1-1/4	11.7/7.4 ²	200	VG1845DN+906AGC	VG1845DN+906IGC	VG1845DN+906GGC
VG1845DP		18.7/11.7 ²		VG1845DP+906AGC	VG1845DP+906IGC	VG1845DP+906GGC
VG1845DR		29.2/14.6		VG1845DR+906AGC	VG1845DR+906IGC	VG1845DR+906GGC
VG1845EP	1-1/2	18.7/11.7 ²	200	VG1845EP+906AGC	VG1845EP+906IGC	VG1845EP+906GGC
VG1845ER		29.2/18.7 ²		VG1845ER+906AGC	VG1845ER+906IGC	VG1845ER+906GGC
VG1845ES		46.8/23.4		VG1845ES+906AGC	VG1845ES+906IGC	VG1845ES+906GGC
VG1845FR	2	29.2/18.7 ²	200	VG1845FR+909AGC	—	VG1845FR+909GGC
VG1845FS		46.8/29.2 ²		VG1845FS+909AGC	—	VG1845FS+909GGC
VG1845FT		73.7/36.8		VG1845FT+909AGC	—	VG1845FT+909GGC

1. To avoid excessive wear or drive time on the motor for the AGC models, use a controller or software that provides a timeout function to remove the signal at the end of rotation (stall).
2. Cv has a characterizing disk.

Table 20: Three-Way Stainless Steel Trim Ball Valves, Spring Return Counterclockwise - Port A (Coil) Open, VA9203/VA9208 Actuators with Switches (Not Rated for Steam Service)

Fluid Temperatures: -22 to 212°F (-30 to 100°C) Not Rated for Steam Service				AC 24 V			AC 85–264 V (VA9203) AC 120 V (VA9208)
				Floating	0 to 10 VDC Proportional	On/Off	On/Off
Valve	Size, in.	Cv (Port A/B)	Close-off psig	Spring Return Port A Open — Valve Spring Return Counterclockwise — Actuator with One Switch			
				VA9203-AGB-2Z	VA9203-GGB-2Z	VA9203-BGB-2	VA9203-BUB-2
VG1845AD	1/2	1.2/0.7 ¹	200	VG1845AD+923AGB	VG1845AD+923GGB	VG1845AD+923BGB	VG1845AD+923BUB
VG1845AE		1.9/1.2 ¹		VG1845AE+923AGB	VG1845AE+923GGB	VG1845AE+923BGB	VG1845AE+923BUB
VG1845AF		2.9/1.9 ¹		VG1845AF+923AGB	VG1845AF+923GGB	VG1845AF+923BGB	VG1845AF+923BUB
VG1845AG		4.7/2.9 ¹		VG1845AG+923AGB	VG1845AG+923GGB	VG1845AG+923BGB	VG1845AG+923BUB
VG1845AL		7.4/4.7 ¹		VG1845AL+923AGB	VG1845AL+923GGB	VG1845AL+923BGB	VG1845AL+923BUB
VG1845AN		11.7/5.8		VG1845AN+923AGB	VG1845AN+923GGB	VG1845AN+923BGB	VG1845AN+923BUB
VG1845BG	3/4	4.7/2.9 ¹	200	VG1845BG+923AGB	VG1845BG+923GGB	VG1845BG+923BGB	VG1845BG+923BUB
VG1845BL		7.4/4.7 ¹		VG1845BL+923AGB	VG1845BL+923GGB	VG1845BL+923BGB	VG1845BL+923BUB
VG1845BN		11.7/5.8		VG1845BN+923AGB	VG1845BN+923GGB	VG1845BN+923BGB	VG1845BN+923BUB
VG1845CL	1	7.4/4.7 ¹	200	VG1845CL+923AGB	VG1845CL+923GGB	VG1845CL+923BGB	VG1845CL+923BUB
VG1845CN		11.7/ 7.4 ¹		VG1845CN+923AGB	VG1845CN+923GGB	VG1845CN+923BGB	VG1845CN+923BUB
VG1845CP		18.7/9.4		VG1845CP+923AGB	VG1845CP+923GGB	VG1845CP+923BGB	VG1845CP+923BUB
Valve	Size, in.	Cv (Port A/B)	Close-off psig	Spring Return Port A Open — Valve Spring Return Counterclockwise — Actuator with Two Switches			
				VA9208-AGC-3	VA9208-GGC-3	VA9208-BGC-3	VA9208-BAC-3
VG1845DN	1-1/4	11.7/ 7.4 ¹	200	VG1845DN+938AGC	VG1845DN+938GGC	VG1845DN+938BGC	VG1845DN+938BAC
VG1845DP		18.7/ 11.7 ¹		VG1845DP+938AGC	VG1845DP+938GGC	VG1845DP+938BGC	VG1845DP+938BAC
VG1845DR		29.2/ 14.6		VG1845DR+938AGC	VG1845DR+938GGC	VG1845DR+938BGC	VG1845DR+938BAC
VG1845EP	1-1/2	18.7/ 11.7 ¹	200	VG1845EP+938AGC	VG1845EP+938GGC	VG1845EP+938BGC	VG1845EP+938BAC
VG1845ER		29.2/ 18.7 ¹		VG1845ER+938AGC	VG1845ER+938GGC	VG1845ER+938BGC	VG1845ER+938BAC
VG1845ES		46.8/ 23.4		VG1845ES+938AGC	VG1845ES+938GGC	VG1845ES+938BGC	VG1845ES+938BAC
VG1845FR	2	29.2/ 18.7 ¹	200	VG1845FR+938AGC	VG1845FR+938GGC	VG1845FR+938BGC	VG1845FR+938BAC
VG1845FS		46.8/ 29.2 ¹		VG1845FS+938AGC	VG1845FS+938GGC	VG1845FS+938BGC	VG1845FS+938BAC
VG1845FT		73.7/ 36.8		VG1845FT+938AGC	VG1845FT+938GGC	VG1845FT+938BGC	VG1845FT+938BAC

1. Cv has a characterizing disk.

Table 21: Three-Way Stainless Steel Trim Ball Valves, Spring Return Clockwise – Port A (Coil) Closed with Switches (Not Rated for Steam Service)

Fluid Temperatures: -22 to 212°F (-30 to 100°C) Not Rated for Steam Service				AC 24 V			AC 85–264 V (VA9203) AC 120 V (VA9208)
				Floating	0 to 10 VDC Proportional	On/Off	On/Off
Valve	Size, in.	Cv (Port A/B)	Closeoff psig	Spring Return Port A Closed — Valve Spring Return Clockwise — Actuator with One Switch			
				VA9203-AGB-2Z	VA9203-GGB-2Z	VA9203-BGB-2	VA9203-BUB-2
VG1845AD	1/2	1.2/0.7 ¹	200	VG1845AD+943AGB	VG1845AD+943GGB	VG1845AD+943BGB	VG1845AD+943BUB
VG1845AE		1.9/1.2 ¹		VG1845AE+943AGB	VG1845AE+943GGB	VG1845AE+943BGB	VG1845AE+943BUB
VG1845AF		2.9/1.9 ¹		VG1845AF+943AGB	VG1845AF+943GGB	VG1845AF+943BGB	VG1845AF+943BUB
VG1845AG		4.7/2.9 ¹		VG1845AG+943AGB	VG1845AG+943GGB	VG1845AG+943BGB	VG1845AG+943BUB
VG1845AL		7.4/4.7 ¹		VG1845AL+943AGB	VG1845AL+943GGB	VG1845AL+943BGB	VG1845AL+943BUB
VG1845AN		11.7/5.8		VG1845AN+943AGB	VG1845AN+943GGB	VG1845AN+943BGB	VG1845AN+943BUB
VG1845BG		3/4		4.7/2.9 ¹	200	VG1845BG+943AGB	VG1845BG+943GGB
VG1845BL	7.4/4.7 ¹		VG1845BL+943AGB	VG1845BL+943GGB		VG1845BL+943BGB	VG1845BL+943BUB
VG1845BN	11.7/5.8		VG1845BN+943AGB	VG1845BN+943GGB		VG1845BN+943BGB	VG1845BN+943BUB
VG1845CL	1	7.4/4.7 ¹	200	VG1845CL+943AGB	VG1845CL+943GGB	VG1845CL+943BGB	VG1845CL+943BUB
VG1845CN		11.7/7.4 ¹		VG1845CN+943AGB	VG1845CN+943GGB	VG1845CN+943BGB	VG1845CN+943BUB
VG1845CP		18.7/9.4		VG1845CP+943AGB	VG1845CP+943GGB	VG1845CP+943BGB	VG1845CP+943BUB
Valve	Size, in.	Cv (Port A/B)	Closeoff psig	Spring Return Port A Closed — Valve Spring Return Clockwise — Actuator with Two Switches			
				VA9208-AGC-3	VA9208-GGC-3	VA9208-BGC-3	VA9208-BAC-3
VG1845DN	1-1/4	11.7/7.4 ¹	200	VG1845DN+958AGC	VG1845DN+958GGC	VG1845DN+958BGC	VG1845DN+958BAC
VG1845DP		18.7/11.7 ¹		VG1845DP+958AGC	VG1845DP+958GGC	VG1845DP+958BGC	VG1845DP+958BAC
VG1845DR		29.2/14.6		VG1845DR+958AGC	VG1845DR+958GGC	VG1845DR+958BGC	VG1845DR+958BAC
VG1845EP	1-1/2	18.7/11.7 ¹	200	VG1845EP+958AGC	VG1845EP+958GGC	VG1845EP+958BGC	VG1845EP+958BAC
VG1845ER		29.2/18.7 ¹		VG1845ER+958AGC	VG1845ER+958GGC	VG1845ER+958BGC	VG1845ER+958BAC
VG1845ES		46.8/23.4		VG1845ES+958AGC	VG1845ES+958GGC	VG1845ES+958BGC	VG1845ES+958BAC
VG1845FR	2	29.2/18.7 ¹	200	VG1845FR+958AGC	VG1845FR+958GGC	VG1845FR+958BGC	VG1845FR+958BAC
VG1845FS		46.8/29.2 ¹		VG1845FS+958AGC	VG1845FS+958GGC	VG1845FS+958BGC	VG1845FS+958BAC
VG1845FT		73.7/36.8		VG1845FT+958AGC	VG1845FT+958GGC	VG1845FT+958BGC	VG1845FT+958BAC

1. Cv has a characterizing disk.

Table 22: Three-Way Stainless Steel Trim Ball Valves, Spring Return Counterclockwise – Port A (Coil) Open, VA9203/VA9208 Actuators with Switches and Optional M9000-561 Thermal Barrier

Fluid Temperatures: -22 to 284°F (-30 to 140°C) Water and 15 psi Saturated Steam				AC 24 V			AC 85–264 V (VA9203) AC 120 V (VA9208)
				Floating	0 to 10 VDC Proportional	On/Off	On/Off
Valve	Size, in.	Cv (Port A/B)	Closeoff psig	Spring Return Port A Open — Valve Spring Return Counterclockwise — Actuator with One Switch			
				VA9203-AGB-2Z	VA9203-GGB-2Z	VA9203-BGB-2	VA9203-BUB-2
VG1845AD	1/2	1.2/0.7 ¹	200	VG1845ADH923AGB	VG1845ADH923GGB	VG1845ADH923BGB	VG1845ADH923BUB
VG1845AE		1.9/1.2 ¹		VG1845AEH923AGB	VG1845AEH923GGB	VG1845AEH923BGB	VG1845AEH923BUB
VG1845AF		2.9/1.9 ¹		VG1845AFH923AGB	VG1845AFH923GGB	VG1845AFH923BGB	VG1845AFH923BUB
VG1845AG		4.7/2.9 ¹		VG1845AGH923AGB	VG1845AGH923GGB	VG1845AGH923BGB	VG1845AGH923BUB
VG1845AL		7.4/4.7 ¹		VG1845ALH923AGB	VG1845ALH923GGB	VG1845ALH923BGB	VG1845ALH923BUB
VG1845AN		11.7/5.8		VG1845ANH923AGB	VG1845ANH923GGB	VG1845ANH923BGB	VG1845ANH923BUB
VG1845BG	3/4	4.7/2.9 ¹	200	VG1845BGH923AGB	VG1845BGH923GGB	VG1845BGH923BGB	VG1845BGH923BUB
VG1845BL		7.4/4.7 ¹		VG1845BLH923AGB	VG1845BLH923GGB	VG1845BLH923BGB	VG1845BLH923BUB
VG1845BN		11.7/5.8		VG1845BNH923AGB	VG1845BNH923GGB	VG1845BNH923BGB	VG1845BNH923BUB
VG1845CL	1	7.4/4.7 ¹	200	VG1845CLH923AGB	VG1845CLH923GGB	VG1845CLH923BGB	VG1845CLH923BUB
VG1845CN		11.7/ 7.4 ¹		VG1845CNH923AGB	VG1845CNH923GGB	VG1845CNH923BGB	VG1845CNH923BUB
VG1845CP		18.7/9.4		VG1845CPH923AGB	VG1845CPH923GGB	VG1845CPH923BGB	VG1845CPH923BUB
Valve	Size, in.	Cv (Port A/B)	Close off psig	Spring Return Port A Open — Valve Spring Return Counterclockwise — Actuator with Two Switches			
				VA9208-AGC-3	VA9208-GGC-3	VA9208-BGC-3	VA9208-BAC-3
VG1845DN	1-1/4	11.7/ 7.4 ¹	200	VG1845DNH938AGC	VG1845DNH938GGC	VG1845DNH938BGC	VG1845DNH938BAC
VG1845DP		18.7/ 11.7 ¹		VG1845DPH938AGC	VG1845DPH938GGC	VG1845DPH938BGC	VG1845DPH938BAC
VG1845DR		29.2/ 14.6		VG1845DRH938AGC	VG1845DRH938GGC	VG1845DRH938BGC	VG1845DRH938BAC
VG1845EP	1-1/2	18.7/ 11.7 ¹	200	VG1845EPH938AGC	VG1845EPH938GGC	VG1845EPH938BGC	VG1845EPH938BAC
VG1845ER		29.2/ 18.7 ¹		VG1845ERH938AGC	VG1845ERH938GGC	VG1845ERH938BGC	VG1845ERH938BAC
VG1845ES		46.8/ 23.4		VG1845ESH938AGC	VG1845ESH938GGC	VG1845ESH938BGC	VG1845ESH938BAC
VG1845FR	2	29.2/ 18.7 ¹	200	VG1845FRH938AGC	VG1845FRH938GGC	VG1845FRH938BGC	VG1845FRH938BAC
VG1845FS		46.8/ 29.2 ¹		VG1845FSH938AGC	VG1845FSH938GGC	VG1845FSH938BGC	VG1845FSH938BAC
VG1845FT		73.7/ 36.8		VG1845FTH938AGC	VG1845FTH938GGC	VG1845FTH938BGC	VG1845FTH938BAC
VG1845DN	1-1/4	11.7/ 7.4 ¹	200	VG1845DNH958AGC	VG1845DNH958GGC	VG1845DNH958BGC	VG1845DNH958BAC
VG1845DP		18.7/ 11.7 ¹		VG1845DPH958AGC	VG1845DPH958GGC	VG1845DPH958BGC	VG1845DPH958BAC
VG1845DR		29.2/ 14.6		VG1845DRH958AGC	VG1845DRH958GGC	VG1845DRH958BGC	VG1845DRH958BAC

1. Cv has a characterizing disk.

Table 23: Three-Way Stainless Steel Trim Ball Valves, Spring Return Clockwise – Port A (Coil) Closed, VA9203/VA9208 Actuators with Switches and Optional M9000-561 Thermal Barrier

Fluid Temperatures: -22 to 284°F (-30 to 140°C) Water and 15 psi Saturated Steam				AC 24 V			AC 85–264 V (VA9203) AC 120 V (VA9208)
				Floating	0 to 10 VDC Proportional	On/Off	On/Off
Valve	Size, in.	Cv (Port A/B)	Closeoff psig	Spring Return Port A Closed — Valve Spring Return Clockwise — Actuator with One Switch			
				VA9203-AGB-2Z	VA9203-GGB-2Z	VA9203-BGB-2	VA9203-BUB-2
VG1845AD	1/2	1.2/0.7	200	VG1845ADH943AGB	VG1845ADH943GGB	VG1845ADH943BGB	VG1845ADH943BUB
VG1845AE		1.9/1.2 ¹		VG1845AEH943AGB	VG1845AEH943GGB	VG1845AEH943BGB	VG1845AEH943BUB
VG1845AF		2.9/1.9 ¹		VG1845AFH943AGB	VG1845AFH943GGB	VG1845AFH943BGB	VG1845AFH943BUB
VG1845AG		4.7/2.9 ¹		VG1845AGH943AGB	VG1845AGH943GGB	VG1845AGH943BGB	VG1845AGH943BUB
VG1845AL		7.4/4.7 ¹		VG1845ALH943AGB	VG1845ALH943GGB	VG1845ALH943BGB	VG1845ALH943BUB
VG1845AN		11.7/5.8		VG1845ANH943AGB	VG1845ANH943GGB	VG1845ANH943BGB	VG1845ANH943BUB
VG1845BG		3/4		4.7/2.9 ¹	200	VG1845BGH943AGB	VG1845BGH943GGB
VG1845BL	7.4/4.7 ¹		VG1845BLH943AGB	VG1845BLH943GGB		VG1845BLH943BGB	VG1845BLH943BUB
VG1845BN	11.7/5.8		VG1845BNH943AGB	VG1845BNH943GGB		VG1845BNH943BGB	VG1845BNH943BUB
VG1845CL	1	7.4/4.7 ¹	200	VG1845CLH943AGB	VG1845CLH943GGB	VG1845CLH943BGB	VG1845CLH943BUB
VG1845CN		11.7/ 7.4 ¹		VG1845CNH943AGB	VG1845CNH943GGB	VG1845CNH943BGB	VG1845CNH943BUB
VG1845CP		18.7/9.4		VG1845CPH943AGB	VG1845CPH943GGB	VG1845CPH943BGB	VG1845CPH943BUB
Valve	Size, in.	Cv (Port A/B)	Closeoff psig	Spring Return Port A Closed — Valve Spring Return Clockwise — Actuator with Two Switches			
				VA9208-AGC-3	VA9208-GGC-3	VA9208-BGC-2	VA9208-BAC-3
VG1845DN	1-1/4	11.7/ 7.4 ¹	200	VG1845DNH958AGC	VG1845DNH958GGC	VG1845DNH958BGC	VG1845DNH958BAC
VG1845DP		18.7/ 11.7 ¹		VG1845DPH958AGC	VG1845DPH958GGC	VG1845DPH958BGC	VG1845DPH958BAC
VG1845DR		29.2/ 14.6		VG1845DRH958AGC	VG1845DRH958GGC	VG1845DRH958BGC	VG1845DRH958BAC
VG1845EP	1-1/2	18.7/ 11.7 ¹	200	VG1845EPH958AGC	VG1845EPH958GGC	VG1845EPH958BGC	VG1845EPH958BAC
VG1845ER		29.2/ 18.7 ¹		VG1845ERH958AGC	VG1845ERH958GGC	VG1845ERH958BGC	VG1845ERH958BAC
VG1845ES		46.8/ 23.4		VG1845ESH958AGC	VG1845ESH958GGC	VG1845ESH958BGC	VG1845ESH958BAC
VG1845FR	2	29.2/ 18.7 ¹	200	VG1845FRH958AGC	VG1845FRH958GGC	VG1845FRH958BGC	VG1845FRH958BAC
VG1845FS		46.8/ 29.2 ¹		VG1845FSH958AGC	VG1845FSH958GGC	VG1845FSH958BGC	VG1845FSH958BAC
VG1845FT		73.7/ 36.8		VG1845FTH958AGC	VG1845FTH958GGC	VG1845FTH958BGC	VG1845FTH958BAC

Table 24: Three-Way Stainless Steel Trim Ball Valves, Spring Return Counterclockwise - Port A (Coil) Open, VA9203/VA9208 Actuators without Switches (Not Rated for Steam Service)

Fluid Temperatures: -22 to 212°F (-30 to 100°C) Not Rated for Steam Service				AC 24 V			AC 85–264 V (VA9203) AC 120 V (VA9208)
				Floating	0 to 10 VDC Proportional	On/Off	On/Off
Valve	Size, in.	Cv (Port A/B)	Closeoff psig	Spring Return Port A Open — Valve Spring Return Counterclockwise - Actuators without Switches			
				VA9203-AGA-2Z	VA9203-GGA-2Z	VA9203-BGA-2	VA9203-BUA-2
VG1845AD	1/2	1.2 ¹	200	VG1845AD+923AGA	VG1845AD+923GGA	VG1845AD+923BGA	VG1845AD+923BUA
VG1845AE		1.9 ¹		VG1845AE+923AGA	VG1845AE+923GGA	VG1845AE+923BGA	VG1845AE+923BUA
VG1845AF		2.9 ¹		VG1845AF+923AGA	VG1845AF+923GGA	VG1845AF+923BGA	VG1845AF+923BUA
VG1845AG		4.7 ¹		VG1845AG+923AGA	VG1845AG+923GGA	VG1845AG+923BGA	VG1845AG+923BUA
VG1845AL		7.4 ¹		VG1845AL+923AGA	VG1845AL+923GGA	VG1845AL+923BGA	VG1845AL+923BUA
VG1845AN		11.7		VG1845AN+923AGA	VG1845AN+923GGA	VG1845AN+923BGA	VG1845AN+923BUA
VG1845BG	3/4	4.7 ¹	200	VG1845BG+923AGA	VG1845BG+923GGA	VG1845BG+923BGA	VG1845BG+923BUA
VG1845BL		7.4 ¹		VG1845BL+923AGA	VG1845BL+923GGA	VG1845BL+923BGA	VG1845BL+923BUA
VG1845BN		11.7		VG1845BN+923AGA	VG1845BN+923GGA	VG1845BN+923BGA	VG1845BN+923BUA
VG1845CL	1	7.4 ¹	200	VG1845CL+923AGA	VG1845CL+923GGA	VG1845CL+923BGA	VG1845CL+923BUA
VG1845CN		11.7 ¹		VG1845CN+923AGA	VG1845CN+923GGA	VG1845CN+923BGA	VG1845CN+923BUA
VG1845CP		18.7		VG1845CP+923AGA	VG1845CP+923GGA	VG1845CP+923BGA	VG1845CP+923BUA
Valve	Size, in.	Cv (Port A/B)	Closeoff psig	Spring Return Port A Open — Valve Spring Return Counterclockwise - Actuators without Switches			
				VA9208-AGA-2	VA9208-GGA-2	VA9208-BGA-3	VA9208-BAA-3
VG1845DN	1-1/4	11.7 ¹	200	VG1845DN+928AGA	VG1845DN+928GGA	VG1845DN+938BGA	VG1845DN+938BAA
VG1845DP		18.7 ¹		VG1845DP+928AGA	VG1845DP+928GGA	VG1845DP+938BGA	VG1845DP+938BAA
VG1845DR		29.2		VG1845DR+928AGA	VG1845DR+928GGA	VG1845DR+938BGA	VG1845DR+938BAA
VG1845EP	1-1/2	18.7 ¹	200	VG1845EP+928AGA	VG1845EP+928GGA	VG1845EP+938BGA	VG1845EP+938BAA
VG1845ER		29.2 ¹		VG1845ER+928AGA	VG1845ER+928GGA	VG1845ER+938BGA	VG1845ER+938BAA
VG1845ES		46.8		VG1845ES+928AGA	VG1845ES+928GGA	VG1845ES+938BGA	VG1845ES+938BAA
VG1845FR	2	29.2 ¹	200	VG1845FR+928AGA	VG1845FR+928GGA	VG1845FR+938BGA	VG1845FR+938BAA
VG1845FS		46.8 ¹		VG1845FS+928AGA	VG1845FS+928GGA	VG1845FS+938BGA	VG1845FS+938BAA
VG1845FT		73.7		VG1845FT+928AGA	VG1845FT+928GGA	VG1845FT+938BGA	VG1845FT+938BAA
VG1845CL	1	7.4 ¹	200	VG1845CL+943AGA	VG1845CL+943GGA	VG1845CL+943BGA	VG1845CL+943BUA
VG1845CN		11.7 ¹		VG1845CN+943AGA	VG1845CN+943GGA	VG1845CN+943BGA	VG1845CN+943BUA
VG1845CP		18.7		VG1845CP+943AGA	VG1845CP+943GGA	VG1845CP+943BGA	VG1845CP+943BUA

1. Cv has a characterizing disk.

Table 25: Three-Way Stainless Steel Trim Ball Valves, Spring Return Clockwise - Port A (Coil) Closed, VA9203/VA9208 Actuators without Switches (Not Rated for Steam Service)

Fluid Temperatures: -22 to 212°F (-30 to 100°C) Not Rated for Steam Service				AC 24 V			AC 85–264 V (VA9203) AC 120 V (VA9208)
				Floating	0 to 10 VDC Proportional	On/Off	On/Off
Valve	Size, in.	Cv (Port A/B)	Closeoff psig	Spring Return Port A Closed — Valve Spring Return Clockwise - Actuators without Switches			
				VA9203-AGA-2Z	VA9203-GGA-2Z	VA9203-BGA-2	VA9203-BUA-2
VG1845AD	1/2	1.2 ¹	200	VG1845AD+943AGA	VG1845AD+943GGA	VG1845AD+943BGA	VG1845AD+943BUA
VG1845AE		1.9 ¹		VG1845AE+943AGA	VG1845AE+943GGA	VG1845AE+943BGA	VG1845AE+943BUA
VG1845AF		2.9 ¹		VG1845AF+943AGA	VG1845AF+943GGA	VG1845AF+943BGA	VG1845AF+943BUA
VG1845AG		4.7 ¹		VG1845AG+943AGA	VG1845AG+943GGA	VG1845AG+943BGA	VG1845AG+943BUA
VG1845AL		7.4 ¹		VG1845AL+943AGA	VG1845AL+943GGA	VG1845AL+943BGA	VG1845AL+943BUA
VG1845AN		11.7		VG1845AN+943AGA	VG1845AN+943GGA	VG1845AN+943BGA	VG1845AN+943BUA
VG1845BG	3/4	4.7 ¹	200	VG1845BG+943AGA	VG1845BG+943GGA	VG1845BG+943BGA	VG1845BG+943BUA
VG1845BL		7.4 ¹		VG1845BL+943AGA	VG1845BL+943GGA	VG1845BL+943BGA	VG1845BL+943BUA
VG1845BN		11.7		VG1845BN+943AGA	VG1845BN+943GGA	VG1845BN+943BGA	VG1845BN+943BUA
VG1845CL	1	7.4 ¹	200	VG1845CL+943AGA	VG1845CL+943GGA	VG1845CL+943BGA	VG1845CL+943BUA
VG1845CN		11.7 ¹		VG1845CN+943AGA	VG1845CN+943GGA	VG1845CN+943BGA	VG1845CN+943BUA
VG1845CP		18.7		VG1845CP+943AGA	VG1845CP+943GGA	VG1845CP+943BGA	VG1845CP+943BUA
Valve	Size, in.	Cv (Port A/B)	Closeoff psig	Spring Return Port A Closed — Valve Spring Return Clockwise - Actuators without Switches			
				VA9208-AGA-2	VA9208-GGA-2	VA9208-BGA-3	VA9208-BAA-3
VG1845DN	1-1/4	11.7 ¹	200	VG1845DN+948AGA	VG1845DN+948GGA	VG1845DN+958BGA	VG1845DN+958BAA
VG1845DP		18.7 ¹		VG1845DP+948AGA	VG1845DP+948GGA	VG1845DP+958BGA	VG1845DP+958BAA
VG1845DR		29.2		VG1845DR+948AGA	VG1845DR+948GGA	VG1845DR+958BGA	VG1845DR+958BAA
VG1845EP	1-1/2	18.7 ¹	200	VG1845EP+948AGA	VG1845EP+948GGA	VG1845EP+958BGA	VG1845EP+958BAA
VG1845ER		29.2 ¹		VG1845ER+948AGA	VG1845ER+948GGA	VG1845ER+958BGA	VG1845ER+958BAA
VG1845ES		46.8		VG1845ES+948AGA	VG1845ES+948GGA	VG1845ES+958BGA	VG1845ES+958BAA
VG1845FR	2	29.2 ¹	200	VG1845FR+948AGA	VG1845FR+948GGA	VG1845FR+958BGA	VG1845FR+958BAA
VG1845FS		46.8 ¹		VG1845FS+948AGA	VG1845FS+948GGA	VG1845FS+958BGA	VG1845FS+958BAA
VG1845FT		73.7		VG1845FT+948AGA	VG1845FT+948GGA	VG1845FT+958BGA	VG1845FT+958BAA

1. Cv has a characterizing disk.

Table 26: Three-Way Stainless Steel Trim Ball Valves, Spring Return Counterclockwise - Port A (Coil) Open, VA9203/VA9208 Actuators without Switches with Optional M9000-561 Thermal Barrier

Fluid Temperatures: -22 to 284°F (-30 to 140°C) Water and 15 psi Steam				AC 24 V			AC 85–264 V (VA9203) AC 120 V (VA9208)
				Floating	0 to 10 VDC Proportional	On/Off	On/Off
Valve	Size, in.	Cv (Port A/B)	Closeoff psig	Spring Return Port A Open — Valve Spring Return Counterclockwise - Actuators without Switches			
				VA9203-AGA-2Z	VA9203-GGA-2Z	VA9203-BGA-2	VA9203-BUA-2
VG1845AD	1/2	1.2 ¹	200	VG1845ADH923AGA	VG1845ADH923GGA	VG1845ADH923BGA	VG1845ADH923BUA
VG1845AE		1.9 ¹		VG1845AEH923AGA	VG1845AEH923GGA	VG1845AEH923BGA	VG1845AEH923BUA
VG1845AF		2.9 ¹		VG1845AFH923AGA	VG1845AFH923GGA	VG1845AFH923BGA	VG1845AFH923BUA
VG1845AG		4.7 ¹		VG1845AGH923AGA	VG1845AGH923GGA	VG1845AGH923BGA	VG1845AGH923BUA
VG1845AL		7.4 ¹		VG1845ALH923AGA	VG1845ALH923GGA	VG1845ALH923BGA	VG1845ALH923BUA
VG1845AN		11.7		VG1845ANH923AGA	VG1845ANH923GGA	VG1845ANH923BGA	VG1845ANH923BUA
VG1845BG	3/4	4.7 ¹	200	VG1845BGH923AGA	VG1845BGH923GGA	VG1845BGH923BGA	VG1845BGH923BUA
VG1845BL		7.4 ¹		VG1845BLH923AGA	VG1845BLH923GGA	VG1845BLH923BGA	VG1845BLH923BUA
VG1845BN		11.7		VG1845BNH923AGA	VG1845BNH923GGA	VG1845BNH923BGA	VG1845BNH923BUA
VG1845CL	1	7.4 ¹	200	VG1845CLH923AGA	VG1845CLH923GGA	VG1845CLH923BGA	VG1845CLH923BUA
VG1845CN		11.7 ¹		VG1845CNH923AGA	VG1845CNH923GGA	VG1845CNH923BGA	VG1845CNH923BUA
VG1845CP		18.7		VG1845CPH923AGA	VG1845CPH923GGA	VG1845CPH923BGA	VG1845CPH923BUA
Valve	Size, in.	Cv (Port A/B)	Closeoff psig	Spring Return Port A Open — Valve Spring Return Counterclockwise - Actuators without Switches			
				VA9208-AGA-2	VA9208-GGA-2	VA9208-BGA-3	VA9208-BAA-3
VG1845DN	1-1/4	11.7 ¹	200	VG1845DNH928AGA	VG1845DNH928GGA	VG1845DNH938BGA	VG1845DNH938BAA
VG1845DP		18.7 ¹		VG1845DPH928AGA	VG1845DPH928GGA	VG1845DPH938BGA	VG1845DPH938BAA
VG1845DR		29.2		VG1845DRH928AGA	VG1845DRH928GGA	VG1845DRH938BGA	VG1845DRH938BAA
VG1845EP	1-1/2	18.7 ¹	200	VG1845EPH928AGA	VG1845EPH928GGA	VG1845EPH938BGA	VG1845EPH938BAA
VG1845ER		29.2 ¹		VG1845ERH928AGA	VG1845ERH928GGA	VG1845ERH938BGA	VG1845ERH938BAA
VG1845ES		46.8		VG1845ESH928AGA	VG1845ESH928GGA	VG1845ESH938BGA	VG1845ESH938BAA
VG1845FR	2	29.2 ¹	200	VG1845FRH928AGA	VG1845FRH928GGA	VG1845FRH938BGA	VG1845FRH938BAA
VG1845FS		46.8 ¹		VG1845FSH928AGA	VG1845FSH928GGA	VG1845FSH938BGA	VG1845FSH938BAA
VG1845FT		73.7		VG1845FTH928AGA	VG1845FTH928GGA	VG1845FTH938BGA	VG1845FTH938BAA

1. Cv has a characterizing disk.

Table 27: Three-Way Stainless Steel Trim Ball Valves, Spring Return Clockwise - Port A (Coil) Closed, VA9203/VA9208 Actuators without Switches with Optional M9000-561 Thermal Barrier

Fluid Temperatures: -22 to 284°F (-30 to 140°C) Water and 15 psi Steam				AC 24 V			AC 85–264 V (VA9203) AC 120 V (VA9208)
				Floating	0 to 10 VDC Proportional	On/Off	On/Off
Valve	Size, in.	Cv (Port A/B)	Closeoff psig	Spring Return Port A Closed — Valve Spring Return Clockwise - Actuators Without Switches			
				VA9203-AGA-2Z	VA9203-GGA-2Z	VA9203-BGA-2	VA9203-BUA-2
VG1845AD	1/2	1.2 ¹	200	VG1845ADH943AGA	VG1845ADH943GGA	VG1845ADH943BGA	VG1845ADH943BUA
VG1845AE		1.9 ¹		VG1845AEH943AGA	VG1845AEH943GGA	VG1845AEH943BGA	VG1845AEH943BUA
VG1845AF		2.9 ¹		VG1845AFH943AGA	VG1845AFH943GGA	VG1845AFH943BGA	VG1845AFH943BUA
VG1845AG		4.7 ¹		VG1845AGH943AGA	VG1845AGH943GGA	VG1845AGH943BGA	VG1845AGH943BUA
VG1845AL		7.4 ¹		VG1845ALH943AGA	VG1845ALH943GGA	VG1845ALH943BGA	VG1845ALH943BUA
VG1845AN		11.7		VG1845ANH943AGA	VG1845ANH943GGA	VG1845ANH943BGA	VG1845ANH943BUA
VG1845BG	3/4	4.7 ¹	200	VG1845BGH943AGA	VG1845BGH943GGA	VG1845BGH943BGA	VG1845BGH943BUA
VG1845BL		7.4 ¹		VG1845BLH943AGA	VG1845BLH943GGA	VG1845BLH943BGA	VG1845BLH943BUA
VG1845BN		11.7		VG1845BNH943AGA	VG1845BNH943GGA	VG1845BNH943BGA	VG1845BNH943BUA
VG1845CL	1	7.4 ¹	200	VG1845CLH943AGA	VG1845CLH943GGA	VG1845CLH943BGA	VG1845CLH943BUA
VG1845CN		11.7 ¹		VG1845CNH943AGA	VG1845CNH943GGA	VG1845CNH943BGA	VG1845CNH943BUA
VG1845CP		18.7		VG1845CPH943AGA	VG1845CPH943GGA	VG1845CPH943BGA	VG1845CPH943BUA
Valve	Size, in.	Cv (Port A/B)	Closeoff psig	Spring Return Port A Closed — Valve Spring Return Clockwise - Actuators without Switches			
				VA9208-AGA-2	VA9208-GGA-2	VA9208-BGA-3	VA9208-BAA-3
VG1845DN	1-1/4	11.7 ¹	200	VG1845DNH948AGA	VG1845DNH948GGA	VG1845DNH958BGA	VG1845DNH958BAA
VG1845DP		18.7 ¹		VG1845DPH948AGA	VG1845DPH948GGA	VG1845DPH958BGA	VG1845DPH958BAA
VG1845DR		29.2		VG1845DRH948AGA	VG1845DRH948GGA	VG1845DRH958BGA	VG1845DRH958BAA
VG1845EP	1-1/2	18.7 ¹	200	VG1845EPH948AGA	VG1845EPH948GGA	VG1845EPH958BGA	VG1845EPH958BAA
VG1845ER		29.2 ¹		VG1845ERH948AGA	VG1845ERH948GGA	VG1845ERH958BGA	VG1845ERH958BAA
VG1845ES		46.8		VG1845ESH948AGA	VG1845ESH948GGA	VG1845ESH958BGA	VG1845ESH958BAA
VG1845FR	2	29.2 ¹	200	VG1845FRH948AGA	VG1845FRH948GGA	VG1845FRH958BGA	VG1845FRH958BAA
VG1845FS		46.8 ¹		VG1845FSH948AGA	VG1845FSH948GGA	VG1845FSH958BGA	VG1845FSH958BAA
VG1845FT		73.7		VG1845FTH948AGA	VG1845FTH948GGA	VG1845FTH958BGA	VG1845FTH958BAA

1. Cv has characterizing disk.

Table 28: Two-Way Plated Brass Trim Ball Valves, Non-Spring Return, VA9104 Electric Actuators without Switches for Fluid Temperatures to 203°F

Fluid Temperature: 23 to 203°F (-5 to 95°C) Closeoff: 200 psig				AC 24 V			
				On/Off (Floating) without Timeout ¹	On/Off (Floating) with Timeout	DC 0 to 10 V Proportional	
End Connection	Valve	Size, in.	Cv	Actuators with M3 Screw Terminals			
				VA9104-AGA-3S	VA9104-IGA-3S	VA9104-GGA-3S	
NPT	VG1241AD	1/2	1.2 ²	VG1241AD+9T4AGA	VG1241AD+9T4IGA	VG1241AD+9T4GGA	
	VG1241AE		1.9 ²	VG1241AE+9T4AGA	VG1241AE+9T4IGA	VG1241AE+9T4GGA	
	VG1241AF		2.9 ²	VG1241AF+9T4AGA	VG1241AF+9T4IGA	VG1241AF+9T4GGA	
	VG1241AG		4.7 ²	VG1241AG+9T4AGA	VG1241AG+9T4IGA	VG1241AG+9T4GGA	
	VG1241AL		7.4 ²	VG1241AL+9T4AGA	VG1241AL+9T4IGA	VG1241AL+9T4GGA	
	VG1241AN		11.7 ²	VG1241AN+9T4AGA	VG1241AN+9T4IGA	VG1241AN+9T4GGA	
	VG1241BG	3/4	4.7 ²	VG1241BG+9T4AGA	VG1241BG+9T4IGA	VG1241BG+9T4GGA	
	VG1241BL		7.4 ²	VG1241BL+9T4AGA	VG1241BL+9T4IGA	VG1241BL+9T4GGA	
	VG1241BN		11.7	VG1241BN+9T4AGA	VG1241BN+9T4IGA	VG1241BN+9T4GGA	
	VG1241CL	1	7.4 ²	VG1241CL+9T4AGA	VG1241CL+9T4IGA	VG1241CL+9T4GGA	
	VG1241CN		11.7 ²	VG1241CN+9T4AGA	VG1241CN+9T4IGA	VG1241CN+9T4GGA	
	VG1241CP		18.7	VG1241CP+9T4AGA	VG1241CP+9T4IGA	VG1241CP+9T4GGA	
	Valve	Size, in.	Cv	Actuators with 120 in. (3.05 m) 18 AWG Plenum Cable			
					VA9104-AGA-2S	VA9104-IGA-2S	VA9104-GGA-2S
	VG1241AD	1/2	1.2 ²	VG1241AD+9A4AGA	VG1241AD+9A4IGA	VG1241AD+9A4GGA	
	VG1241AE		1.9 ²	VG1241AE+9A4AGA	VG1241AE+9A4IGA	VG1241AE+9A4GGA	
	VG1241AF		2.9 ²	VG1241AF+9A4AGA	VG1241AF+9A4IGA	VG1241AF+9A4GGA	
	VG1241AG		4.7 ²	VG1241AG+9A4AGA	VG1241AG+9A4IGA	VG1241AG+9A4GGA	
	VG1241AL		7.4 ²	VG1241AL+9A4AGA	VG1241AL+9A4IGA	VG1241AL+9A4GGA	
	VG1241AN		11.7	VG1241AN+9A4AGA	VG1241AN+9A4IGA	VG1241AN+9A4GGA	
	VG1241BG	3/4	4.7 ²	VG1241BG+9A4AGA	VG1241BG+9A4IGA	VG1241BG+9A4GGA	
	VG1241BL		7.4 ²	VG1241BL+9A4AGA	VG1241BL+9A4IGA	VG1241BL+9A4GGA	
	VG1241BN		11.7	VG1241BN+9A4AGA	VG1241BN+9A4IGA	VG1241BN+9A4GGA	
	VG1241CL	1	7.4 ²	VG1241CL+9A4AGA	VG1241CL+9A4IGA	VG1241CL+9A4GGA	
VG1241CN	11.7 ²		VG1241CN+9A4AGA	VG1241CN+9A4IGA	VG1241CN+9A4GGA		
VG1241CP	18.7		VG1241CP+9A4AGA	VG1241CP+9A4IGA	VG1241CP+9A4GGA		

1. To avoid excessive wear or drive time on the motor for the AGx models, use a controller or software that provides a timeout function to remove the signal at the end of rotation.
2. Cv has a characterizing disk.

Table 29: Two-Way Plated Brass Trim Ball Valves, Non-Spring Return, M9106/M9109 Electric Actuators For Fluid Temperatures to 203°F

Fluid Temperature: 23 to 203°F (-5 to 95°C) Closeoff: 200 PSIG				AC 24 V			
				On/Off (Floating) With Timeout ¹	On/Off (Floating) With Timeout	DC 0 to 10 V Proportional	
End Connection	Valve	Size, in.	Cv	Actuators Without Switches			
				M9106-AGA-2 M9109-AGA-2	M9106-IGA-2	M9106-GGA-2 M9109-GGA-2	
NPT	VG1241AD	1/2	1.2 ²	VG1241AD+906AGA	VG1241AD+906IGA	VG1241AD+906GGA	
	VG1241AE		1.9 ²	VG1241AE+906AGA	VG1241AE+906IGA	VG1241AE+906GGA	
	VG1241AF		2.9 ²	VG1241AF+906AGA	VG1241AF+906IGA	VG1241AF+906GGA	
	VG1241AG		4.7 ²	VG1241AG+906AGA	VG1241AG+906IGA	VG1241AG+906GGA	
	VG1241AL		7.4 ²	VG1241AL+906AGA	VG1241AL+906IGA	VG1241AL+906GGA	
	VG1241AN		11.7	VG1241AN+906AGA	VG1241AN+906IGA	VG1241AN+906GGA	
	VG1241BG	3/4	4.7 ²	VG1241BG+906AGA	VG1241BG+906IGA	VG1241BG+906GGA	
	VG1241BL		7.4 ²	VG1241BL+906AGA	VG1241BL+906IGA	VG1241BL+906GGA	
	VG1241BN		11.7	VG1241BN+906AGA	VG1241BN+906IGA	VG1241BN+906GGA	
	VG1241CL	1	7.4 ²	VG1241CL+906AGA	VG1241CL+906IGA	VG1241CL+906GGA	
	VG1241CN		11.7 ²	VG1241CN+906AGA	VG1241CN+906IGA	VG1241CN+906GGA	
	VG1241CP		18.7	VG1241CP+906AGA	VG1241CP+906IGA	VG1241CP+906GGA	
	VG1241DN	1-1/4	11.7 ²	VG1241DN+906AGA	VG1241DN+906IGA	VG1241DN+906GGA	
	VG1241DP		18.7 ²	VG1241DP+906AGA	VG1241DP+906IGA	VG1241DP+906GGA	
	VG1241DR		29.2	VG1241DR+906AGA	VG1241DR+906IGA	VG1241DR+906GGA	
	VG1241EP	1-1/2	18.7 ²	VG1241EP+906AGA	VG1241EP+906IGA	VG1241EP+906GGA	
	VG1241ER		29.2 ²	VG1241ER+906AGA	VG1241ER+906IGA	VG1241ER+906GGA	
	VG1241ES		46.8	VG1241ES+906AGA	VG1241ES+906IGA	VG1241ES+906GGA	
	VG1241FR	2	29.2 ²	VG1241FR+909AGA	—	VG1241FR+909GGA	
	VG1241FS		46.8 ²	VG1241FS+909AGA	—	VG1241FS+909GGA	
	VG1241FT		73.7	VG1241FT+909AGA	—	VG1241FT+909GGA	
		Valve	Size, in.	Cv	Actuators With Two Switches		
					M9106-AGC-2 M9109-AGC-2	M9106-IGC-2	M9106-GGC-2 M9109-GGC-2
		VG1241AD	1/2	1.2 ²	VG1241AD+906AGC	VG1241AD+906IGC	VG1241AD+906GGC
		VG1241AE		1.9 ²	VG1241AE+906AGC	VG1241AE+906IGC	VG1241AE+906GGC
		VG1241AF		2.9 ²	VG1241AF+906AGC	VG1241AF+906IGC	VG1241AF+906GGC
		VG1241AG		4.7 ²	VG1241AG+906AGC	VG1241AG+906IGC	VG1241AG+906GGC
		VG1241AL		7.4 ²	VG1241AL+906AGC	VG1241AL+906IGC	VG1241AL+906GGC
	VG1241AN	11.7		VG1241AN+906AGC	VG1241AN+906IGC	VG1241AN+906GGC	
	VG1241BG	3/4	4.7 ²	VG1241BG+906AGC	VG1241BG+906IGC	VG1241BG+906GGC	
	VG1241BL		7.4 ²	VG1241BL+906AGC	VG1241BL+906IGC	VG1241BL+906GGC	
	VG1241BN		11.7	VG1241BN+906AGC	VG1241BN+906IGC	VG1241BN+906GGC	
	VG1241CL	1	7.4 ²	VG1241CL+906AGC	VG1241CL+906IGC	VG1241CL+906GGC	
	VG1241CN		11.7 ²	VG1241CN+906AGC	VG1241CN+906IGC	VG1241CN+906GGC	
	VG1241CP		18.7	VG1241CP+906AGC	VG1241CP+906IGC	VG1241CP+906GGC	
	VG1241DN	1-1/4	11.7 ²	VG1241DN+906AGC	VG1241DN+906IGC	VG1241DN+906GGC	
	VG1241DP		18.7 ²	VG1241DP+906AGC	VG1241DP+906IGC	VG1241DP+906GGC	
	VG1241DR		29.2	VG1241DR+906AGC	VG1241DR+906IGC	VG1241DR+906GGC	
	VG1241EP	1-1/2	18.7 ²	VG1241EP+906AGC	VG1241EP+906IGC	VG1241EP+906GGC	
	VG1241ER		29.2 ²	VG1241ER+906AGC	VG1241ER+906IGC	VG1241ER+906GGC	
	VG1241ES		46.8	VG1241ES+906AGC	VG1241ES+906IGC	VG1241ES+906GGC	
	VG1241FR	2	29.2 ²	VG1241FR+909AGC	—	VG1241FR+909GGC	
	VG1241FS		46.8 ²	VG1241FS+909AGC	—	VG1241FS+909GGC	
	VG1241FT		73.7	VG1241FT+909AGC	—	VG1241FT+909GGC	

1. To avoid excessive wear or drive time on the motor for the AGx models, use a controller or software that provides a timeout function to remove the signal at the end of rotation.
2. Cv has a characterizing disk.

Table 30: Shipping Weights, lb (kg)

Valve Code Number	Description	Shipping Weight, lb (kg)
VG12xxAx	1/2 in. (DN15) Two-Way Forged Brass Ball Valve	0.8 (0.36)
VG12xxBx	3/4 in. (DN20) Two-Way Forged Brass Ball Valve	1.0 (0.45)
VG12xxCx	1 in. (DN25) Two-Way Forged Brass Ball Valve	1.8 (0.82)
VG12xxDx	1-1/4 in. (DN32) Two-Way Forged Brass Ball Valve	2.3 (1.04)
VG12xxEx	1-1/2 in. (DN40) Two-Way Forged Brass Ball Valve	3.8 (1.73)
VG12xxFx	2 in. (DN50) Two-Way Forged Brass Ball Valve	5.0 (2.3)
VG18xxAx	1/2 in. (DN15) Three-Way Forged Brass Ball Valve	1.25 (0.57)
VG18xxBx	3/4 in. (DN20) Three-Way Forged Brass Ball Valve	1.5 (0.68)
VG18xxCx	1 in. (DN25) Three-Way Forged Brass Ball Valve	2.75 (1.25)
VG18xxDx	1-1/4 in. (DN32) Three-Way Forged Brass Ball Valve	4.25 (1.93)
VG18xxEx	1-1/2 in. (DN40) Three-Way Forged Brass Ball Valve	6.25 (2.84)
VG18xxFx	2 in. (DN50) Three-Way Forged Brass Ball Valve	8.2 (3.7)

Table 31: Repair Parts

Linkage	Replacement Description	Replacement Part Code Number
M9000-520	Anti-Rotation Slider, Includes Carriage Screw, Washers, and Wing Nut	M9000-600
	Mounting Screws and Nuts; Includes Four M5 (5 mm) x 16 mm Machine Screws and Four M5 (5 mm) Serrated Washer Head Nuts	M9000-601
	Drive Shaft	M9000-602
	Manual Handle; Includes Handle and a No. 4 Thread-Forming PLASTITE Screw	M9000-603
M9000-551	Linkage with Handle for VA9104 Series Actuators	Unit Replacement
M2000-560	Linkage for VA9203/VA9208 Series Actuators	Unit Replacement
M2000-561	Thermal Barrier for VA9104/VA9203/VA9208 Series Actuators	Unit Replacement

Application Overview

Available in sizes 1/2 through 2 in. (DN15 through DN50), VG1000 Series Ball Valves are designed specifically for automated commercial HVAC service. These valves feature a forged brass body with either a chrome-plated brass ball for water or glycol solutions to 203°F (95°C), or a 300 Series stainless steel ball for high temperature water to 284°F (140°C) and saturated steam to 15 psi. The Amodel Flow Characterizing Disk maintains equal percentage Flow Characteristics for optimum temperature control, as shown in Figure 2. The blowout-proof stem and mounting flange, combined with an innovative double O-ring stem seal and self-centering stem bushing design (shown in Figure 3) provide quick and easy electric actuator field mounting while ensuring long life and leak-free valve performance. The specially engineered,

graphite-reinforced PTFE seat with flexible PTFE seat design (backed with EPDM O-rings) significantly reduces the operating torque, allowing the smallest possible electric actuator available to provide the force required for the specific application. All valve and actuator assemblies provide 200 psig (1,379 kPa) closeoff pressure while ensuring operation after long idle periods. Because of their cost-effective, reliable design, VG1000 Series Ball Valves are maintenance free.

VG1000 Series Ball Valves are designed for factory or field mounting to a wide variety of Johnson Controls® M9000 and VA9000 Series Electric Actuators. Control signal selections include:

- floating point without timeout
- on/off and floating point
- on/off
- proportional

VA9000 Series Electric Actuators include mounting hardware for direct coupling to VG1000 Series Ball Valves. M9000 Series Electric Actuators require additional Valve Linkage Kits. See Table 27 for valid valve, actuator, and linkage kit combinations for assembly in the field.

Valve End Connection

VG1000 Series 1-1/4, 1-1/2, and 2 in. (DN32, DN40, and DN50) valves are available with NPT threaded ends only.

VG1000 Series 1/2, 3/4, and 1 in. (DN15, DN20, and DN25) valves are available in one of three end connections:

- NPT Threaded
- Sweat end for copper tubing
- Press end for copper tubing

Press end connected valves are designed for installation using RIDGID Pressing Tool Technology manufactured by the Ridgid Tool Corporation for use with the ProPress fitting system. Press end connections afford significant installation savings. Additional information on these tools can be found at www.ridgid.com.

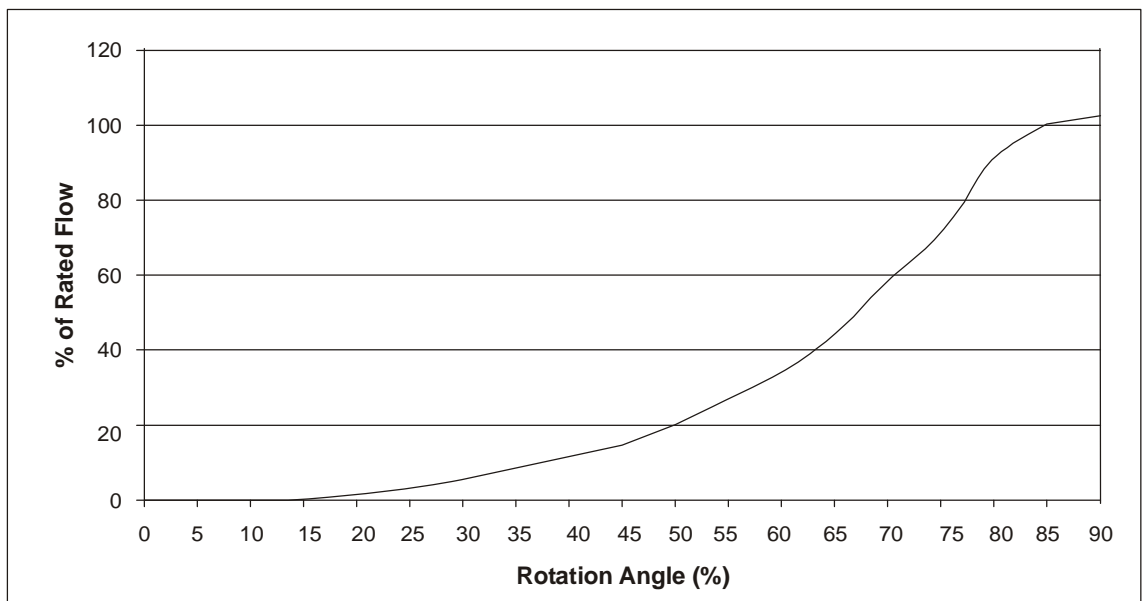

Figure 2: Typical Two-Way VG1000 Series Ball Valve with Characterizing Disk Flow

See Figure 3 for typical VG1000 internal composition.

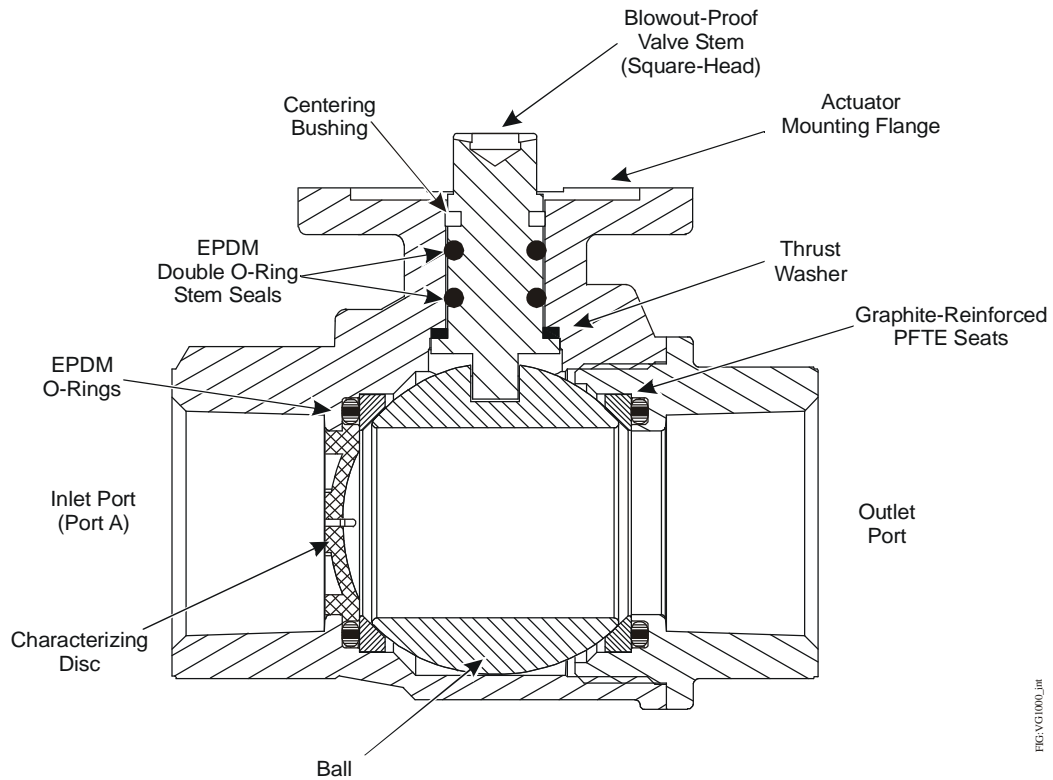
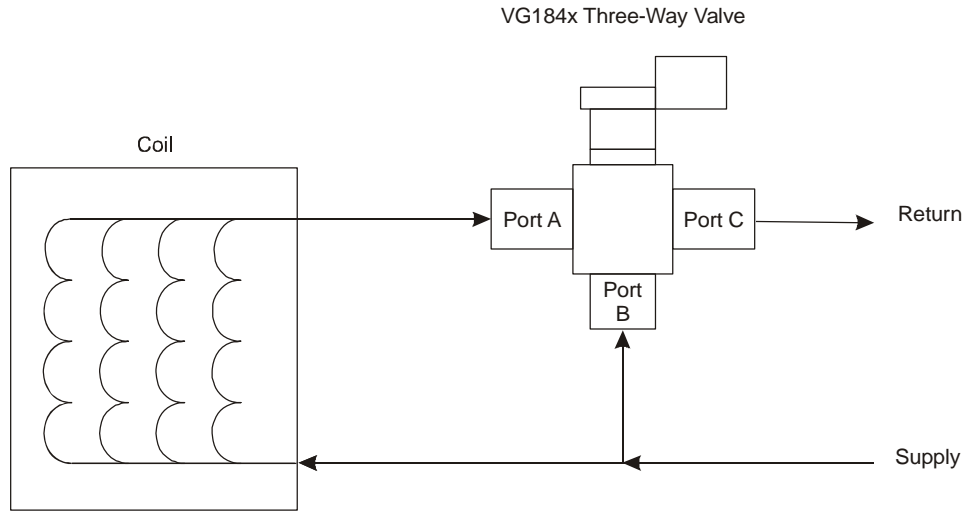
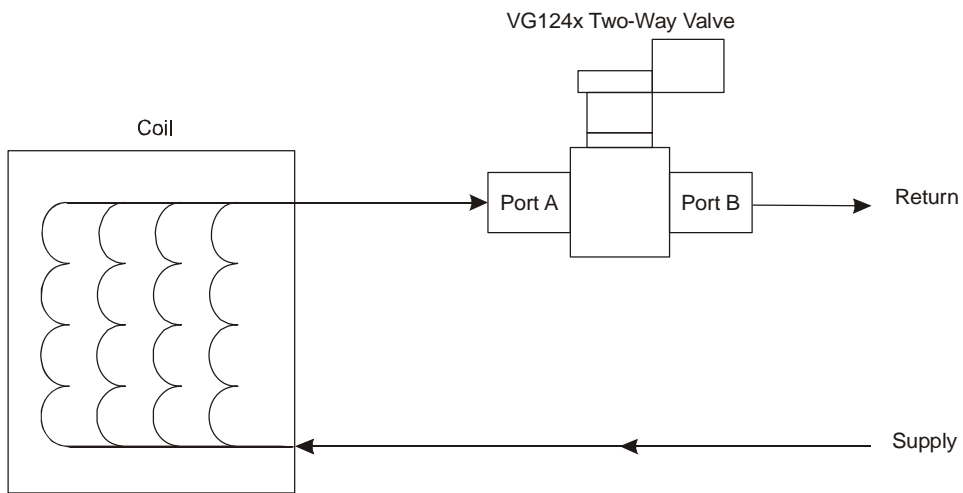

Figure 3: Internal View of a Typical VG1000 Series Ball Valve

See Figure 4 for typical piping applications.



Typical Three-Way Ball Valve Application



Typical Two-Way Ball Valve Application

Note: Mount the valve downstream from the coil to minimize heat transfer to the actuator.

Figure 4: Typical VG1000 Piping

FIG.VG1000_13PP4

IMPORTANT: The VG1000 Series Valves are intended to control saturated steam, hot water, and chilled water flow under normal equipment operating conditions. Where failure or malfunction of the VG1000 Series Valve could lead to personal injury or property damage to the controlled equipment or other property, additional precautions must be designed into the system. Incorporate and maintain other devices such as supervisory or alarm systems or safety or limit controls, intended to warn of or protect against failure or malfunction of the VG1000 Series Valve.

Electric Actuator Control Signal Action

Two-way VG1000 Series Ball Valves are fully open when the electric actuator is fully Counterclockwise (CCW) and fully closed when the electric actuator is fully Clockwise (CW). For three-way valves, the Port A and common port are fully open when the electric actuator is fully CCW, as shown in Figure 5. Port B and common port are fully open when the actuator is fully CW, as shown in Figure 6.

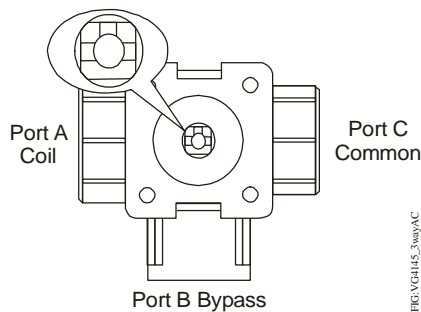

Figure 5: VG1841 or VG1845 Series Three-Way Ball Valve (Port A Connected to Port C)

Note: VG1841 and VG1845 three-way ball valves have a different port configuration (as shown in Figure 5 and Figure 6) from the older VG1644 Series three-way ball valves (Figure 7), and you must change the piping to convert them to the new series of valves.

For non-spring return and spring-to-open proportional control models in the direct-acting mode, a minimum control signal drives the electric actuator to the fully CCW position, whereas a maximum control signal drives the electric actuator to the fully CW position.

For spring-to-close proportional control models in the direct-acting mode, a minimum control signal drives the electric actuator to the fully CW position, whereas a maximum control signal drives the electric actuator to the fully CCW position.

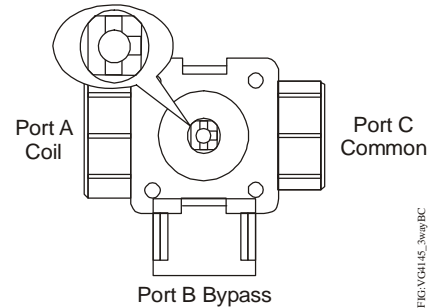

Figure 6: VG1841 or VG1845 Series Three-Way Ball Valve (Port B Connected to Port C)

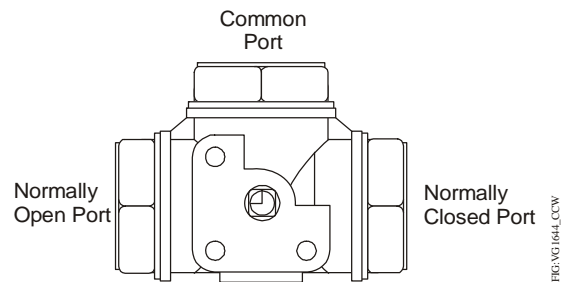

Figure 7: Top View of VG1644 Series Three-Way Ball Valve (Actuator Fully CCW)

For non-spring return floating or on/off (floating) control models, a control signal to Terminal 2 (or wire 2) of a VA9104 or an M91xx Series Actuator drives the electric actuator to the fully CW position. Likewise, a control signal to Terminal 3 (or wire 3) of a VA9104 or an M91xx Series Actuator drives the electric actuator to the fully CCW position.

A control signal to Wire 3 of side A mounted (away from the valve) VA9203 or VA9208 Series actuated spring-to-open floating control valve assembly drives the electric actuator to the fully CW position. Likewise, a control signal to Wire 4 of a floating CCW-face VA9203 Series or VA9208 Series Actuator, or removal of the control signal from Wire 3 of an on/off CCW-face VA9203 Series or VA9208 Series actuated spring-to-open valve assembly, drives the electric actuator to the fully CCW position.

A control signal to Wire 3 of a CW-face (mounted away from the valve) VA9203 Series or VA9208 Series actuated spring-to-close floating control valve assembly drives the electric actuator to the fully CCW position. Likewise, a control signal to Wire 4 of a floating CW-face VA9203 Series or VA9208 Series Actuator, or removal of the control signal from Wire 3 of an on/off CW-face VA9203 Series or VA9208 Series actuated spring-to-close valve assembly, drives the electric actuator to the fully CW position.

Electric Actuator Selection

VG1000 Series Ball Valves are designed for factory or field mounting to a variety of M9000 and VA9000 Series Actuators. VA9000 Series Actuators include all hardware necessary for attachment to the valve. M9000 Series Actuators require an additional linkage. Refer to Table 32.

Note: To avoid excessive wear or drive time on the motor for VA9104, M9104, M9106, and M9109 AGx models, use a controller and/or software that provides a timeout function to remove the signal at the end of rotation (stall). The IGx and GGx models have an auto shutoff to avoid excessive wear or drive time on the motor.

For more information on these electric actuator series as well as details on models available, refer to the following documents:

- *VA9104-xGA-2S, -3S Series Electric Non-Spring Return Valve Actuators Product Bulletin (LIT-12011050)*
- *M9104-xGA-2S, -3S Series Electric Non-Spring Return Actuators Product Bulletin (LIT-1201742)*
- *M9106-xGx-2 Series Electric Non-spring Return Actuators Product Bulletin (LIT-2681123)*
- *M9109 Series Electric Non-spring Return Actuators Product Bulletin (LIT-120112)*
- *VA9203 Series Electric Spring Return Actuator Product Bulletin (LIT-12011702)*

- *VA9208 Series Electric Spring Return Actuator Product Bulletin (LIT-12011622)*

Linkage Kit and Weather Shield Selection

The M9000-551 and M9000-561 Valve Linkage Kits and M9000-341 Weather Shield are designed specifically for field mounting Johnson Controls M(VA)9104 Series Non-Spring Return and M(VA)9203 and M(VA)9208 Series Spring Return Electric Actuators to VG1000 Series Ball Valves.

The M9000-516 Valve Linkage Kit and M9000-330 Weather Shield is designed specifically for field mounting Johnson Controls M9108 Series Non-Spring Return Electric Actuators to 1-1/4 to 2 in. VG1000 Series Ball Valves. For 1/2 to 1 in. VG1000 Series Ball Valves, use a VA9104 and M9000-341 Weather Shield. See Table 36 for valve, actuator, linkage, and weather shield combinations.

For more information on the M9000-520 Linkage Kit, refer to the *M9000-520 Ball Valve Linkage Kit Product Bulletin (LIT-1201547)* or the *M9000-520 Ball Valve Linkage Kit Installation Instructions (Part No. 14-1297-5)*.

For more information on the M9000-551 Linkage Kit, refer to the *M9000-551 Ball Valve Linkage Kit Installation Instructions (Part No. 34-636-1816)*.

For more information on the M9000-330 Weather Shield, refer to the *M9000-330 and M9000-340 Series Weather Shield Enclosures Installation Instructions (Part No. 14-1330-26)*.

For more information on the M9000-341 Weather Shield, refer to the *M9000-341 Valve Weather Shield Kit Installation Instructions (Part No. 34-636-2235)*.

For more information on the M9000-560 Ball Valve Linkage, refer to the *M9000-560 Ball Valve Linkage Kit and M9000-561 Thermal Barrier Installation Instructions (Part No. 34-636-2227)*.

Table 32: Valid Ball Valve, Electric Actuator, Linkage Kit, and Weather Shield Combinations (for Assembly in the Field) (Part 1 of 2)

Valve Size, in. (DN)	Valve Code Numbers			Actuator Base Number ¹	Linkage Kit Code Number	Weather Shield
	NPT End Connection	Sweat End Connection	Press End Connection			
1/2 (DN15)	VG1241Ax VG1245Ax VG1841Ax VG1845Ax	VG1275Ax VG1875Ax	VG1291Ax VG1295Ax VG1891Ax VG1895Ax	VA9104 ²	None Required (Fluid Temperature ≤212°F)	M9000-341
					M9000-561 (Fluid Temperature ≤284°F)	
				M9104	M9000-551 (Fluid Temperature ≤212°F)	
				M9106	M9000-520	
				M9108	M9000-516	M9000-330
				VA9203	None Required (Fluid Temperature ≤212°F)	M9000-341
					M9000-561 (Fluid Temperature ≤284°F)	
				3/4 (DN20)	VG1241Bx VG1245Bx VG1841Bx VG1845Bx	VG1275Bx VG1875Bx
	M9000-561 (Fluid Temperature ≤284°F)					
M9104	M9000-551 (Fluid Temperature ≤212°F)					
M9106	M9000-520					
M9108	M9000-516	M9000-330				
VA9203	None Required (Fluid Temperature ≤212°F)	M9000-341				
	M9000-561 (Fluid Temperature ≤284°F)					

Table 32: Valid Ball Valve, Electric Actuator, Linkage Kit, and Weather Shield Combinations (for Assembly in the Field) (Part 2 of 2)

Valve Size, in. (DN)	Valve Code Numbers			Actuator Base Number ¹	Linkage Kit Code Number	Weather Shield
	NPT End Connection	Sweat End Connection	Press End Connection			
1 (DN25)	VG1241Cx VG1245Cx VG1841Cx VG1845Cx	VG1271Cx VG1275Cx VG1871Cx VG1875Cx	VG1291Cx VG1295Cx VG1891Cx VG1895Cx	VA9104	None Required (Fluid Temperature ≤212°F)	M9000-341
					M9000-561 (Fluid Temperature ≤284°F)	
				M9104	M9000-551	
				M9106	M9000-520	
				M9108	M9000-516	M9000-330
				VA9203	None Required (Fluid Temperature ≤212°F)	M9000-341
					M9000-561 (Fluid Temperature ≤284°F)	
1-1/4 (DN32)	VG1241Dx VG1245Dx VG1841Dx VG1845Dx			M9106	M9000-520	
				M9108	M9000-516	M9000-330
				VA9208	None Required (Fluid Temperature ≤212°F)	M9000-341
					M9000-561 (Fluid Temperature ≤284°F)	
1-1/2 (DN40)	VG1241Ex VG1245Ex VG1841Ex VG1845Ex			M9106	M9000-520	
				M9108	M9000-516	M9000-330
				VA9208	None Required (Fluid Temperature ≤212°F)	M9000-341
					M9000-561 (Fluid Temperature ≤284°F)	
2 (DN50)	VG1241Fx VG1245Fx VG1841Fx VG1845Fx			M9109	M9000-520	
				M9108	M9000-516	M9000-330
				VA9208	None Required (Fluid Temperature ≤212°F)	M9000-341
					M9000-561 (Fluid Temperature ≤284°F)	

1. VA9104, M9104, M9106, M9108, M9109 and M9106 Series Actuators are non-spring return; and VA9203 and VA9208 Series Actuators are spring return. Note: VA9104, M9104, VA9203, and VA9208 have a maximum fluid temperature limit of 212°F (100°C). The VA9104, M9104, VA9203, and VA9208 temperatures can be increased to 284°F (140°C) or 15 psi steam with the addition of the M9000-561 thermal barrier.
2. To avoid excessive wear or drive time on the motor for VA9104, M9104, M9106, and M9109 AGx models, use a controller and/or software that provides a timeout function to remove the signal at the end of rotation (stall). The IGx and GGx models have an automatic shutoff to avoid excessive wear or drive time on the motor.

See Figure 8 for dimension drawings of the Non-Spring Return VA9104 Series Actuated VG1241, VG1245, VG1841, and VG1845 Series NPT End Connection Ball Valves. See Table 33 and Table 34 for specific model linkage dimensions.

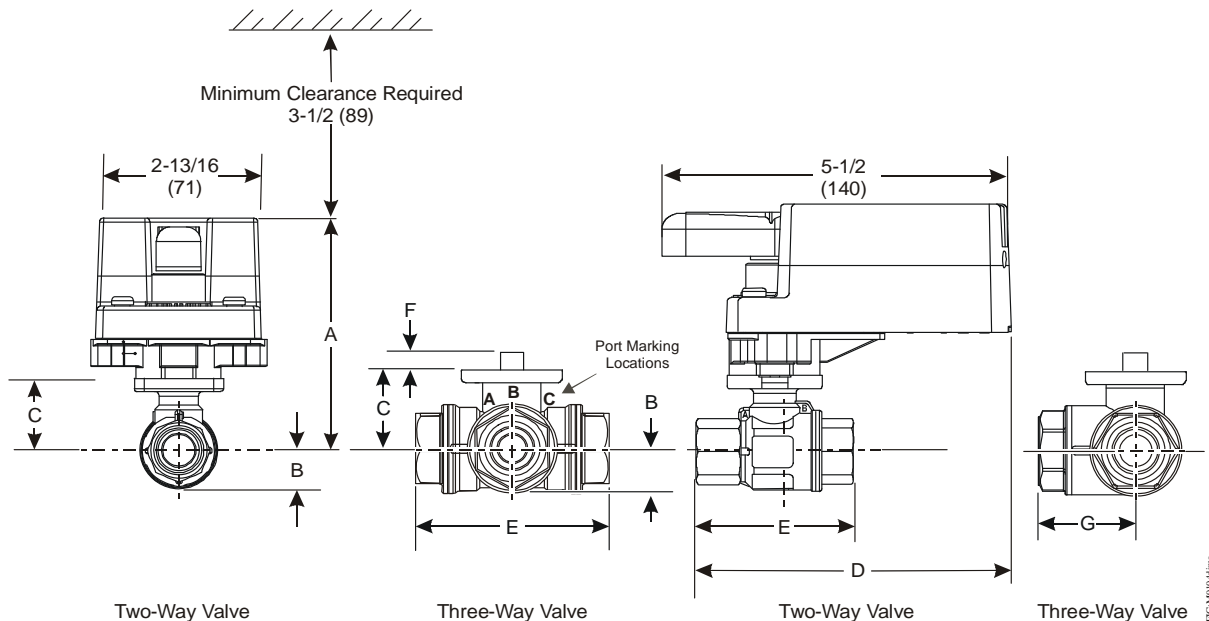

Figure 8: VA9104 Actuated VG1241, VG1245, VG1841, and VG1845 Series Ball Valve with NPT End Connections Dimensions, in. (mm)

Table 33: VA9104 or M9104 Actuated VG1241, VG1245, VG1841, and VG1845 Series Ball Valve with Optional M9000-551 Linkage Dimensions, in. (mm)

Valve Size, in. (DN) ¹	A	B	C	D	E	F	G
1/2 (DN15)	3-7/8 (98)	21/32 (17)	1-7/32 (31)	5-7/64 (129)	2-33/64 (64)	11/32 (9)	1-1/4 (32)
3/4 (DN20)	3-7/8 (98)	21/32 (17)	1-7/32 (31)	5-7/32 (133)	2-51/64 (71)	11/32 (9)	1-13/32 (36)
1 (DN25)	3-11/16 (100)	3/4 (19)	1-19/64 (33)	5-9/16 (141)	3-13/32 (87)	11/32 (9)	1-11/16 (43)

1. Port A must always be connected to the coil (Figure 8).

Table 34: VA9104 Actuated VG1275 and VG1875 Series Ball Valve with Sweat End Connections and VA9104 Actuated VG1295 and VG1895 Series Ball Valves with Press End Connections Dimensions, in. (mm)

Valve Size, in. (DN) ¹	A	B	C	D	E	F	G
1/2 (DN15)	3-7/8 (98)	21/32 (17)	1-7/32 (31)	5-45/64 (145)	3-25/32 (96)	11/32 (9)	2-13/16 (55)
3/4 (DN20)	3-7/8 (98)	21/32 (17)	1-7/32 (31)	5-57/64 (150)	4-3/32 (104)	11/32 (9)	2-15/32 (62)
1 (DN25)	3-15/16 (100)	3/4 (19)	1-19/64 (33)	6-1/8 (156)	4 21/32 (118)	11/32 (9)	2-27/32 (72)

1. Port A must always be connected to the coil (Figure 8).

See Figure 9 for dimensions of the Non-Spring Return VA9104 Series Actuated VG1241, VG1245, VG1841, and VG1845 Series NPT End Connection Ball Valve with optional M9000-561 Thermal Barrier installed. See Table 35 for specific model dimensions.

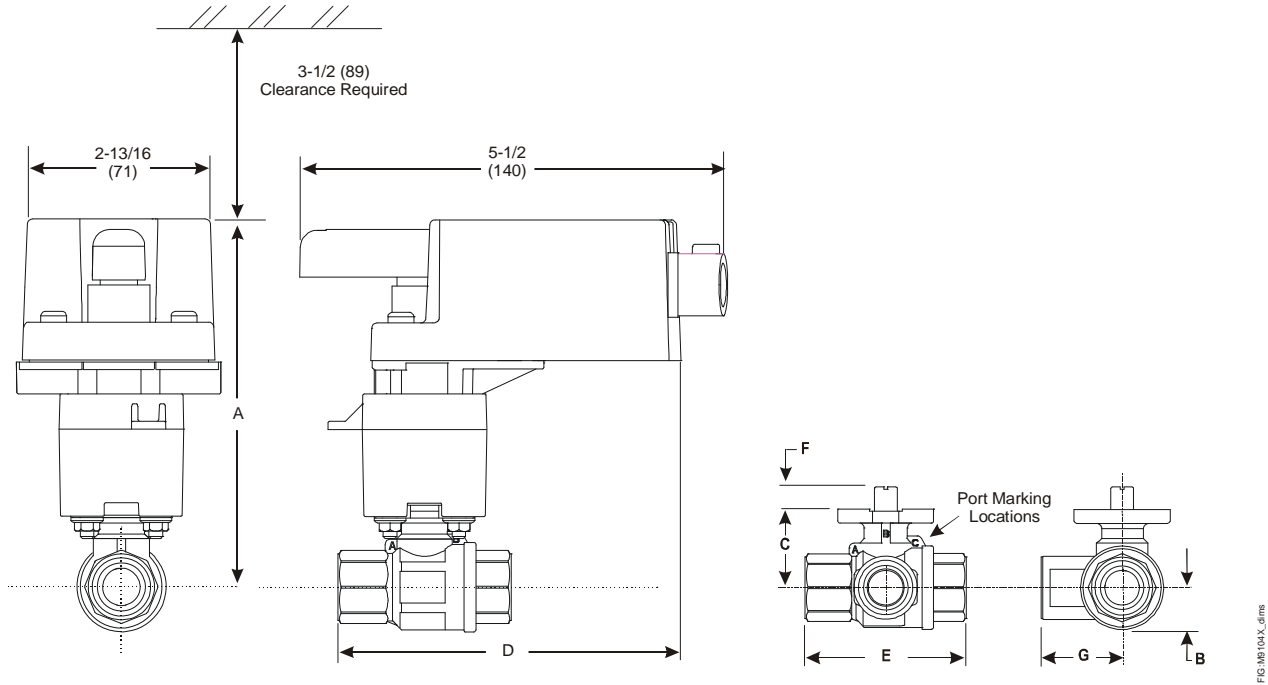

Figure 9: Field-Installed VA9104 Series Electric Actuator Dimensions with Optional M9000-561 Thermal Barrier Dimensions, in. (mm)

Table 35: VA9104 Actuated VG1241, VG1245, VG1841, and VG1845 Series NPT Ball Valves with Optional M9000-561 Thermal Barrier Installed Dimensions, in. (mm)

Valve Size, in. (DN) ¹	A	B	C	D	E	F	G
1/2 (DN15)	5-11/32 (135)	21/32 (17)	1-7/32 (31)	5-45/64 (145)	3-25/32 (96)	11/32 (9)	1-1/4 (32)
3/4 (DN20)	5-11/32 (135)	21/32 (17)	1-7/32 (31)	5-57/64 (150)	4-3/32 (104)	11/32 (9)	1-13/32 (36)
1 (DN25)	5-27/64 (137)	3/4 (19)	1-19/64 (33)	6-1/8 (156)	4-41/64 (118)	11/32 (9)	1-45/46 (43)

1. On models with the flow-characterizing disk, the disk is located in Port A. Port A must be the inlet.

See Figure 10 for dimensions of the Spring Return VA9203 Series Actuated VG1241, VG1245, VG1841, and VG1845 Series NPT End Connection Ball Valves. See Table 36 and Table 37 for specific model linkage dimensions.

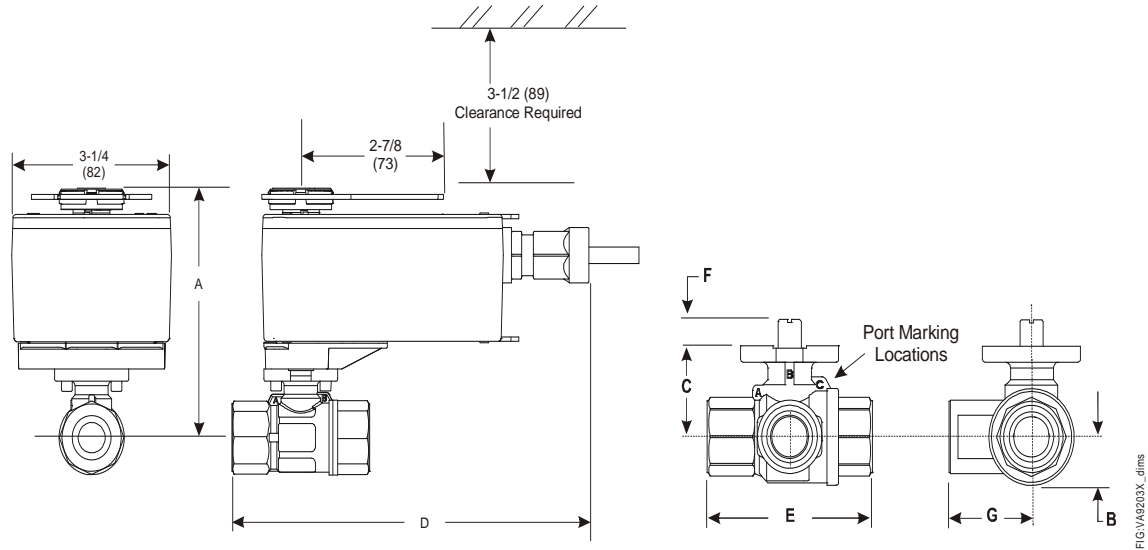

Figure 10: VA9203 Actuated VG1241, VG1245, VG1841, and VG1845 Series Ball Valve with NPT End Connections Dimensions, in. (mm)

Table 36: VA9203 Actuated VG1241, VG1245, VG1841, and VG1845 Series Ball Valve with NPT End Connections Dimensions, in. (mm)

Valve Size, in. (DN) ¹	A	B	C	D	E	F	G
1/2 (DN15)	4-1/4 (108)	21/32 (17)	1-7/32 (31)	6-23/32 (171)	2-33/64 (64)	11/32 (9)	1-1/4 (32)
3/4 (DN20)	4-1/4 (108)	21/32 (17)	1-7/32 (31)	6-7/8 (175)	2-51/64 (71)	11/32 (9)	1-13/32 (36)
1 (DN25)	4-9/32 (109)	3/4 (19)	1-19/64 (33)	7-7/64 (181)	3-13/32 (87)	11/32 (9)	1-45/64 (43)

1. Port A must always be connected to the coil.

Table 37: VA9203 Actuated VG1271, VG1275, VG1871, and VG1875 Series Sweat Ball Valve and VA9203 Actuated VG1291, VG1295, VG1891, and VG1895 Series Press Ball Valve Dimensions, in. (mm)

Valve Size, in. (DN) ¹	A	B	C	D	E	F	G
1/2 (DN15)	4-5/8 (117)	21/32 (17)	1-7/32 (31)	7-13/64 (183)	3-25/32 (96)	11/32 (9)	1-1/4 (32)
3/4 (DN20)	4-5/8 (117)	21/32 (17)	1-7/32 (31)	7-3/4 (197)	4-3/32 (104)	11/32 (9)	1-13/32 (36)
1 (DN25)	4-11/16 (119)	3/4 (19)	1-19/64 (33)	8-3/16 (208)	4-41/64 (118)	11/32 (9)	1-45/64 (43)

1. Port A must always be connected to the coil.

See Figure 11 for dimensions of the VA9203 Spring Return Series Actuated VG1241, VG1245, VG1841, and VG1845 Series NPT End Connection Ball Valves with optional M9000-561 Thermal Barrier installed. See Table 38 for specific model linkage dimensions.

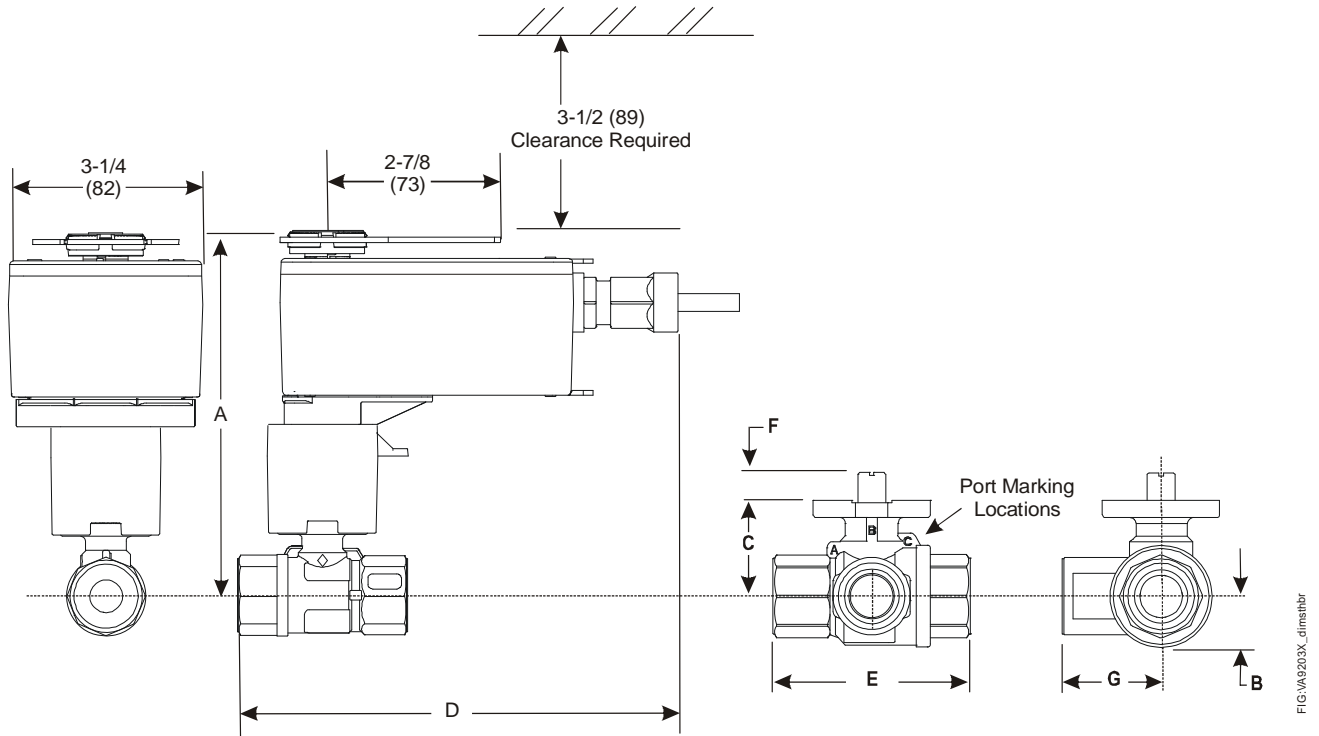

Figure 11: Spring Return VA9203 Actuated VG1241, VG1245, VG1841, and VG1845 Series Ball Valve with Optional M9000-561 Thermal Barrier Installed Dimensions, in. (mm)

Table 38: VA9203 Actuated VG1241, VG1245, VG1841, and VG1845 Series NPT Ball Valve with Optional Thermal Barrier Installed Dimensions, in. (mm)

Valve Size in. (DN) ¹	A	B	C	D	E	F	G
1/2 (DN15)	6 (152)	21/32 (17)	1-7/32 (31)	6-31/32 (177)	2-33/64 (64)	11/32 (9)	1-1/4 (32)
3/4 (DN20)	6 (152)	21/32 (17)	1-7/32 (31)	7-1/8 (181)	2-51/64 (71)	11/32 (9)	1-13/32 (36)
1 (DN25)	6-1/16 (154)	3/4 (19)	1-19/64 (33)	7-31/64 (190)	3-13/32 (87)	11/32 (9)	1-45/64 (43)

1. Port A must always be connected to the coil.

See Figure 12 for dimensions of the Non-Spring Return M9106 or M9109 Actuated VG1241, VG1245, VG1841, and VG1845 Series Ball Valve with M9000-520 Linkage. See Table 39 for specific model linkage dimensions.

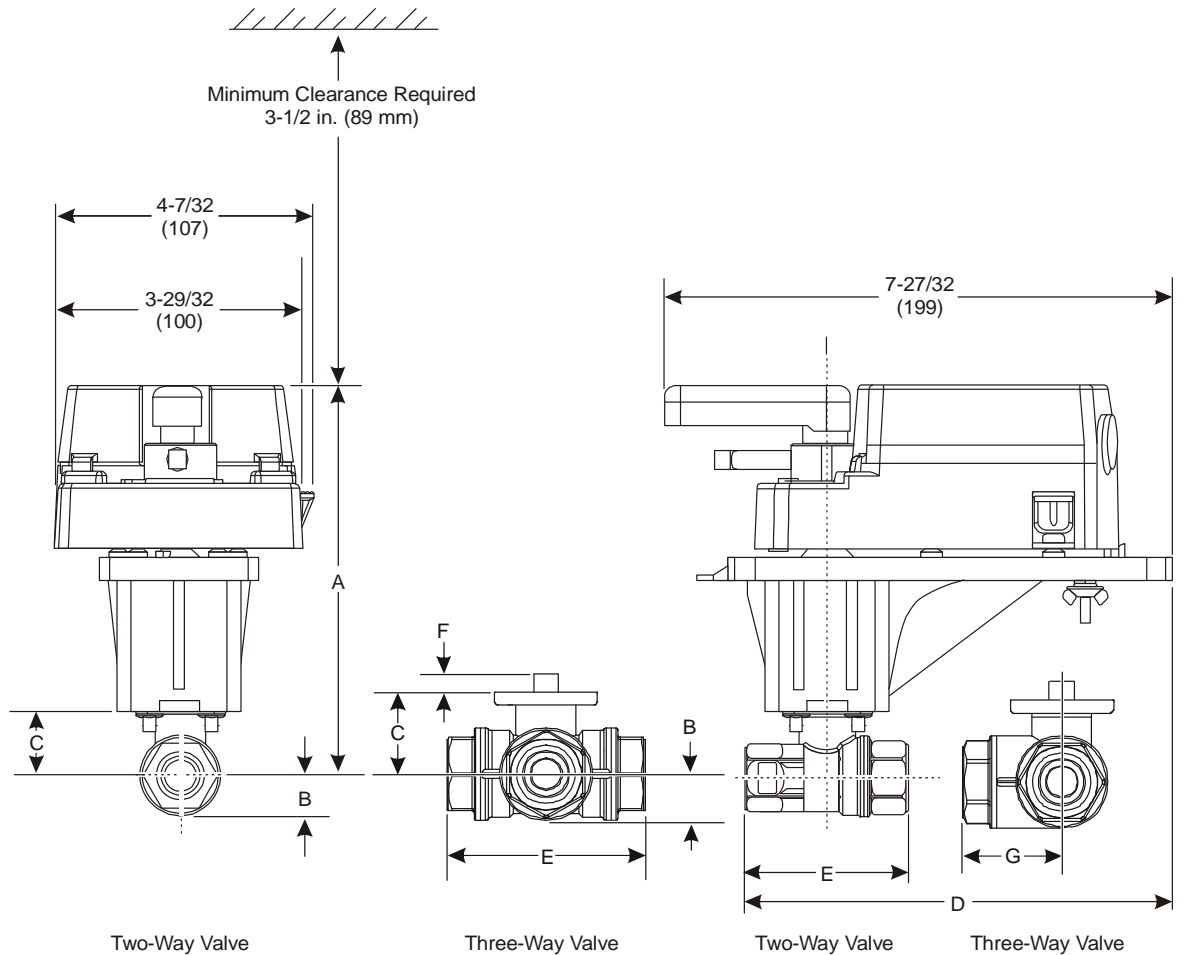

Figure 12: Non-Spring Return M9106 or M9109 Actuated VG1241, VG1245, VG1841, and VG1845 Series Ball Valve with M9000-520 Linkage Dimensions, in. (mm)

Table 39: M9106 and M9109 Actuated VG1241, VG1245, VG1841, and VG1845 Series Ball Valve with M9000-520 Linkage Dimensions, in. (mm)

Valve Size, in. (DN) ¹	A	B	C	D	E	F	G
1/2 (DN15)	6-19/64 (160)	21/32 (17)	1-7/32 (31)	6-49/64 (172)	2-33/64 (64)	11/32 (9)	1-1/4 (32)
3/4 (DN20)	6-19/64 (160)	21/32 (17)	1-7/32 (31)	6-29/32 (175)	2-51/64 (71)	11/32 (9)	1-13/32 (36)
1 (DN 25)	6-3/8 (162)	3/4 (19)	1-19/64 (33)	7-13/64 (183)	3-13/32 (87)	11/32 (9)	1-11/16 (43)
1-1/4 (DN32)	6-13/16 (173)	1-1/32 (26)	1-23/32 (44)	7-15/32 (190)	3-15/16 (100)	11/32 (9)	2 (51)
1-1/2 (DN40)	6-31/32 (177)	1-9/64 (29)	1-57/64 (48)	7-43/64 (195)	4-21/64 (110)	11/32 (9)	2-1/8 (54)
2 (DN50)	7-11/64 (182)	1-15/32 (37)	2-1/16 (53)	7-59/64 (201)	4-27/32 (123)	11/32 (9)	2-9/16 (65)

1. On models with the flow-characterizing disk, the disk is located in Port A. Port A must be the inlet.

See Figure 13 for dimensions of the VA9208 Spring Return Actuated VG1241, VG1245, VG1841, and VG1845 Series NPT End Connection Ball Valves. See Table 40 for specific model linkage dimensions.

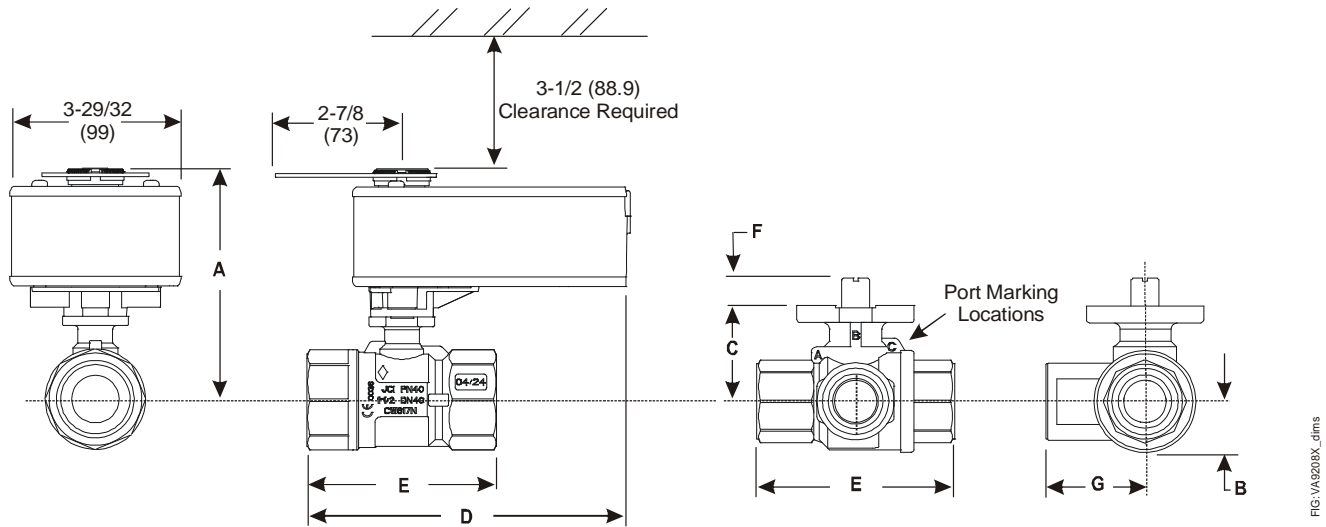

Figure 13: Spring Return VA9208 Actuated VG1241, VG1245, VG1841, and VG1845 Series Ball Valve Dimensions, in. (mm)

Table 40: VA9208 Actuated VG1241, VG1245, VG1841, and VG1845 Series Ball Valve Dimensions, in. (mm)

Valve Size in. (DN)	Valve Style ¹	A	B	C	D	E	F	G
1-1/4 (DN32)	All	7-11/16 (195)	1-1/32 (26)	1-23/32 (44)	7-5/32 (182)	3-15/16 (100)	11/32 (9)	1-31/32 (50)
1-1/2 (DN40)	All	7-7/8 (200)	1-9/64 (29)	1-57/64 (48)	7-3/8 (187)	4-21/64 (110)	11/32 (9)	2-11/64 (55)
2 (DN50)	2-way	8-1/32 (204)	1-15/32 (37)	2-1/8 (54)	7-19/32 (193)	4-27/32 (123)	11/32 (9)	2-27/64 (62)
	3-way				7-7/8 (200)			

1. Port A must always be connected to the coil (see Figure 10).

See Figure 14 for dimensions of the Spring Return VA9208 Actuated VG1241, VG1245, VG1841, and VG1845 Series NPT End Connection Ball Valves with M9000-561 Thermal Barrier. See Table 41 for specific model linkage dimensions.

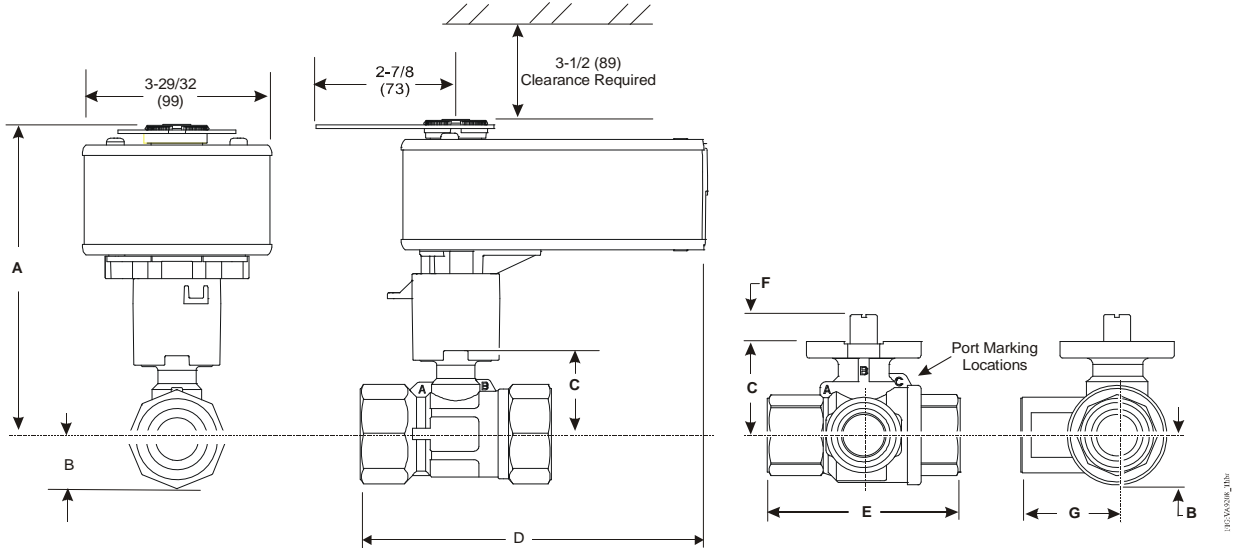

Figure 14: Spring Return VA9208 Actuated VG1241, VG1245, VG1841, and VG1845 Series Ball Valve with Optional M9000-561 Thermal Barrier Installed Dimensions, in. (mm)

Table 41: VA9208 Actuated VG1241, VG1245, VG1841, and VG1845 Series Ball Valve with Optional M9000-561 Thermal Barrier Installed Dimensions, in. (mm)

Valve Size in. (DN) ¹	Valve Style	A	B	C	D	E	F	G
1-1/4 (DN32)	All	9-17/64 (235)	1-1/32 (26)	1-23/32 (44)	7-1/4 (184)	3-15/16 (100)	11/32 (9)	1-31/32 (50)
1-1/2 (DN40)	All	9-15/16 (240)	1-9/64 (29)	1-57/64 (48)	7-7/16 (189)	4-21/64 (110)	11/32 (9)	2-11/64 (55)
2 (DN50)	2-way	9-31/32 (244)	1-15/32 (37)	2-1/8 (54)	7-11/16 (195)	4-27/32 (123)	11/32 (9)	N/A
	3-way				7-7/8 (200)			2-27/64 (62)

1. Port A must always be connected to the coil (Figure 11).

See Figure 15 for dimensions of the Non-Spring Return M91xx Series Actuated VG1241, VG1245, VG1841, and VG1845 Series Ball Valve with M9000-516 Linkage and Field Installed M9000-330 Weather Shield Dimensions.

See Table 42 for specific model linkage dimensions.

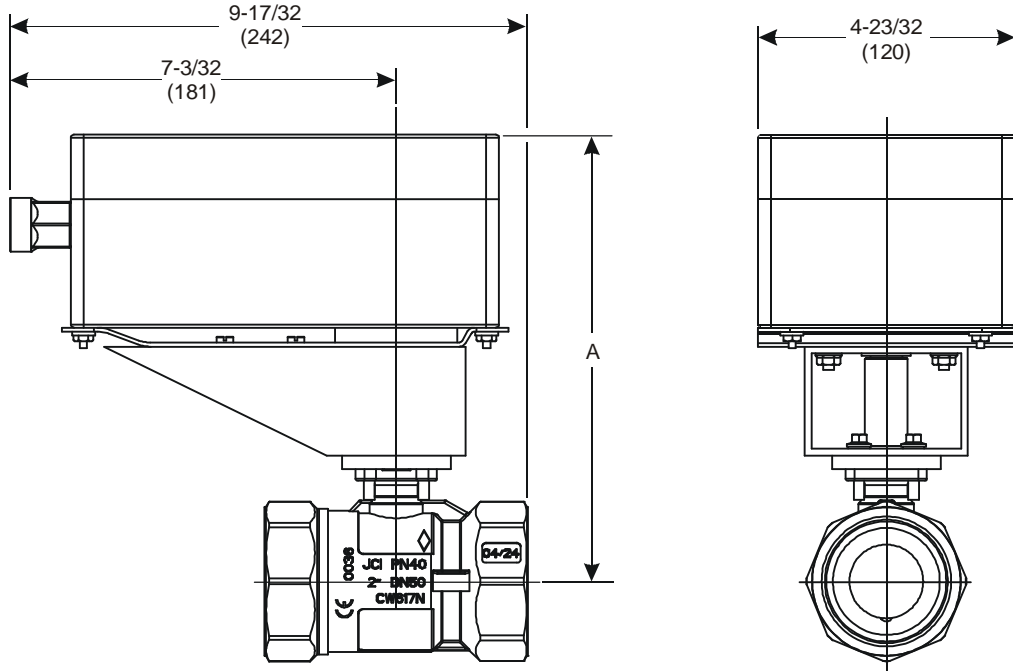

FIG M91xx_m9000330ws

Figure 15: Non-Spring Return M91xx Series Actuated VG1241, VG1245, VG1841, and VG1845 Series Ball Valve with M9000-516 Linkage and Field Installed M9000-330 Weather Shield Dimensions, in. (mm)

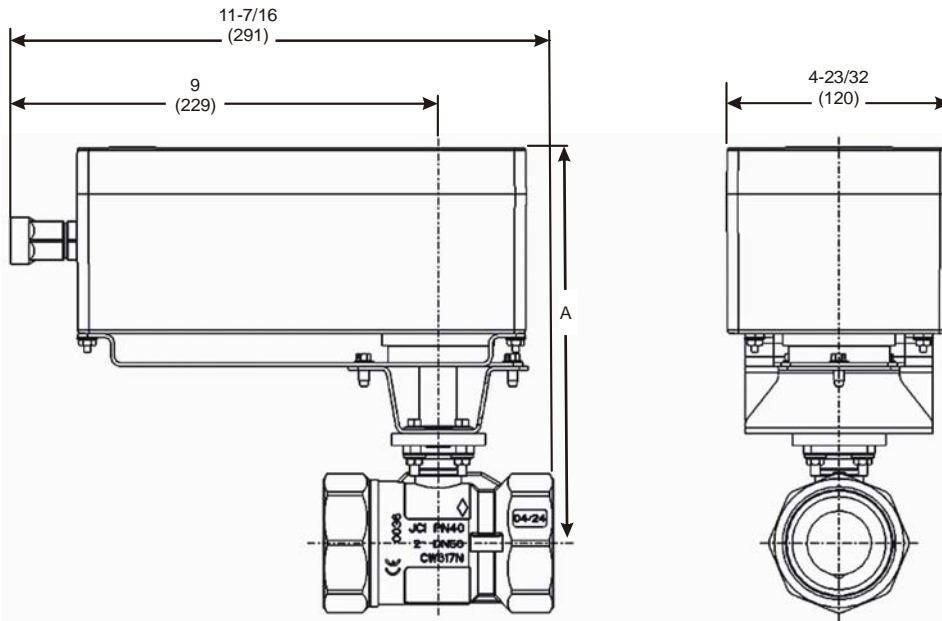

Figure 16: Non-Spring Return VA9104 Series and Spring Return VA920x Series Actuated VG1241, VG1245, VG1841, and VG1845 Series Ball Valve and Field Installed M9000-341 Weather Shield Dimensions, in. (mm)

Table 42: M9000 Series Actuated VG1241, VG1245, VG1841, and VG1845 Series Ball Valve with Weather Shield Dimensions, in. (mm)

Valve Size, in. (DN)	A	
	M91xx	VA9104 and VA920x
1/2 (DN15)	7-3/8 (187)	7-1/2 (191)
3/4 (DN20)	7-3/8 (187)	7-1/2 (191)
1 (DN25)	7-7/16 (189)	7-37/64 (192)
1-1/4 (DN32)	7-7/8 (200)	8 (203)
1-1/2 (DN40)	8-1/32 (204)	8-11/64 (208)
2 (DN50)	8-7/32 (209)	8-11/32 (212)

Technical Specifications

VG1000 Series Forged Brass Ball Valves (Part 1 of 2)

Service¹		Hot Water, Chilled Water, 50/50 Glycol Solutions, and 15 psig (103 kPa) Saturated Steam for HVAC Systems
Fluid Temperature Limits	Water	VG12x1 and VG18x1 Series: 23 to 203°F (-5 to 95°C) VG12x5 and VG18x5 Series: -22 to 284°F (-30 to 140°C)
	Steam	VG12x1 Series: Not Rated for Steam Service VG12x5 Series: 15 psig (103 kPa) at 250°F (121°C)
Maximum Actuator Fluid Temperature Limits	212°F (100°C)	VA9104
		VA9203
		VA9208
		M9104 with M9000-551 Linkage
	284°F (140°C)	M9106 or M9109 with M9000-520 Linkage
		VA9104 with M9000-561 Thermal Barrier VA9203 or VA9208 with M9000-561 Thermal Barrier
Valve Body Pressure/ Temperature Rating	Water	VG1241, VG1245, VG1841, and VG1845 Series: 580 psig (3,996 kPa) at 203°F (95°C) (PN40) 464 psig (3,196 kPa) at 284°F (140°C) (PN40)
		VG1275 and VG1875 Series: 300 psig (2,067 kPa)
		VG1295 and VG1895 Series: 300 psig (2,067 kPa)
	Steam	15 psig (103 kPa) Saturated Steam
Maximum Closeoff Pressure		200 psig (1,378 kPa)
Maximum Recommended Operating Pressure Drop		50 psi Maximum Differential Pressure for Valves with Characterized Flow Control Disk and 30 psi Maximum for Quiet Service Ball Valves
Flow Characteristics	Two-Way	Equal Percentage
	Three-Way	Equal Percentage Flow Characteristics of In-line Port A (Coil) and Linear Flow Characteristics of Angle Port B (Bypass)
Rangeability²		Greater than 500:1
Minimum Ambient Operating Temperature	-4°F (-20°C)	VA9104 and M9104 Series Non-Spring Return Actuators M9106, M9108, and M9109 Series Non-Spring Return Actuators
	-22°F (-30°C)	VA9203 Series Spring Return Actuator
	-40°F (-40°C)	VA9208 Series Spring Return Actuator
Maximum Ambient Operating Temperature³ (Limited by the Actuator and Linkage)	Direct Mount or With M9000-561 Thermal Barrier	140°F (60°C): VA9104 Series Non-Spring Return Actuators VA9203 and VA9208 Series Spring Return Actuators
	M9000-551 Linkage	140°F (60°C): M9104 Series Non-Spring Return Actuators
	M9000-516	122°F (50°C): M9108 Series Non-Spring Return Actuators
	M9000-520 Series Linkage	125°F (52°C): M9106 and M9109 Series Non-Spring Return Actuators
Leakage		0.01% of Maximum Flow per ANSI/FCI 70-2, Class 4 (Two- and Three-Way Control Port) 1% of Maximum Flow for Three-Way Bypass Port

VG1000 Series Forged Brass Ball Valves (Part 2 of 2)

End Connections		National Pipe Thread (NPT): 1/2 to 2 in. (DN15 to DN50) Sweat: 1/2 to 1 in. (DN15 to DN25) Use a low melting point solder. Press (ProPress compatible): 1/2 to 1 in. (DN15 to DN25) (Press end connections are designed to work with RIDGID pressing tools.)
Materials	Body	Forged Brass
	Ball	VG12x1 and VG18x1 Series: Chrome Plated Brass VG12x5 and VG18x5 Series: 300 Series Stainless Steel
	Blowout-Proof Stem	VG12x1 and VG18x1 Series: Nickel Plated Brass VG12x5 and VG18x5 Series: 300 Series Stainless Steel
	Seats	Graphite-Reinforced PTFE with Ethylene Propylene Diene Monomer (EPDM) O-Ring Backing
	Stem Seals	EPDM Double O-Rings
	Characterizing Disk	Amodel AS-1145HS Polyphthalamide Resin

1. Proper water treatment is recommended; refer to the VDI 2035 Standard.
2. Rangeability is defined as the ratio of maximum controllable flow to minimum controllable flow.
3. In steam applications, install the valve with the stem horizontal to the piping and wrap the valve and piping with insulation.

The performance specifications are nominal and conform to acceptable industry standards. For application at conditions beyond these specifications, consult the local Johnson Controls office. Johnson Controls, Inc. shall not be liable for damages resulting from misapplication or misuse of its products.



Building Efficiency
507 E. Michigan Street, Milwaukee, WI 53202

Metasys® and Johnson Controls® are registered trademarks of Johnson Controls, Inc. All other marks herein are the marks of their respective owners. © 2011 Johnson Controls, Inc.