

ACVATIX™

2- and 3-port valves with flanged connections, PN 16

VVF42.., VVF42..K, VXF42..



VVF42..
VVF42..K



VXF42..

From the large-stroke valve line

- Control valves for medium temperatures from -10...150 °C
- Valve body of grey cast iron EN-GJL-250
- DN 15...150
- k_{vs} 1.6...400 m³/h
- Flange type 21, Flange design B
- VVF42..K with pressure compensation to handle high differential pressure
- Equipable with electro-motoric actuators SAX.., SAV.. or electro-hydraulic actuators SKD.., SKB.., SKC..

Use

In boiler, district heating and refrigeration plants, cooling towers, heating groups, in ventilation and air-handling units as control or shutoff valves.
For use in closed hydraulic circuits (observe cavitation).











Type summary

Valves	Actuators				SAX.. ¹⁾	SKD..	SKB..	SAV.. ¹⁾	SKC..															
	Stroke				20 mm				40 mm															
PN 16	Positioning force				800 N	1000 N	2800 N	1600 N	2800 N															
	Data sheet				N4501	N4561	N4564	N4503	N4566															
	Stock no.	DN	k _{vs} [m ³ /h]	S _v	Δp _s	Δp _{max}	Δp _s	Δp _{max}	Δp _s	Δp _{max}	Δp _s	Δp _{max}	Δp _s	Δp _{max}										
					[kPa]																			
VVF42.15-1.6	S55204-V100	15	1.6	> 50	1600	400	1600	400	1600	400	-	-	-	-										
VVF42.15-2.5	S55204-V101	15	2.5																					
VVF42.15-4	S55204-V102	15	4																					
VVF42.20-6.3	S55204-V103	20	6.3																					
VVF42.25-6.3	S55204-V104	25	6.3																					
VVF42.25-10	S55204-V105	25	10																					
VVF42.32-16	S55204-V106	32	16	> 100	900	-	-	-	-	-	-	-	-	-										
VVF42.40-16	S55204-V107	40	16												550	750	1200	1250	400					
VVF42.40-25	S55204-V108	40	25																					
VVF42.50-31.5	S55204-V109	50	31.5												350	300	450	1200	750					
VVF42.50-40	S55204-V110	50	40																					
VVF42.65-50	S55204-V111	65	50												200	150	250	200	700	450				
VVF42.65-63	S55204-V112	65	63																					
VVF42.80-80	S55204-V113	80	80												125	75	175	125	450	250	225			
VVF42.80-100	S55204-V114	80	100																					
VVF42.100-125	S55204-V115	100	125												-	-	-	-	-	-	160	125	300	250
VVF42.100-160	S55204-V116	100	160																					
VVF42.125-200	S55204-V117	125	200												125	90	190	160						
VVF42.125-250	S55204-V118	125	250																					
VVF42.150-315	S55204-V119	150	315	80	60	125	100																	
VVF42.150-400	S55204-V120	150	400																					

Valves	Actuators				SAX.. ¹⁾	SKD..	SKB..	SAV.. ¹⁾	SKC..						
	Stroke				20 mm				40 mm						
PN 16	Positioning force				800 N	1000 N	2800 N	1600 N	2800 N						
	Data sheet				N4501	N4561	N4564	N4503	N4566						
	Stock no.	DN	k _{vs} [m ³ /h]	S _v	Δp _s	Δp _{max}	Δp _s	Δp _{max}	Δp _s	Δp _{max}	Δp _s	Δp _{max}	Δp _s	Δp _{max}	
					[kPa]										
-5...150 °C															
VVF42.50-40K	S55204-V121	50	40	> 100	1600	400	1600	400	1600	400	-	-	-	-	
VVF42.65-63K	S55204-V122	65	63												
VVF42.80-100K	S55204-V123	80	100												
VVF42.100-160K	S55204-V124	100	160		-	-	-	-	-	-	1600	400	1600	400	
VVF42.125-250K	S55204-V125	125	250												
VVF42.150-360K	S55204-V126	150	360								1400				

¹⁾ Permissible medium temperature (coupled valve) -25...130 °C - up to 150 °C in horizontal mounting position.

Valves	Actuators				SAX.. ¹⁾	SKD..	SKB..	SAV.. ¹⁾	SKC..						
	Stroke				20 mm				40 mm						
PN 16	Positioning force				800 N	1000 N	2800 N	1600 N	2800 N						
	Data sheet				N4501	N4561	N4564	N4503	N4566						
	Stock no.	DN	k _{vs} [m ³ /h]	S _v	Δp _{max} [kPa]										
					A → AB B		AB → A B		A → AB B		AB → A B		A → AB B		AB → A B
-10...150 °C															
VVF42.15-1.6	S55204-V127	15	1.6	> 50	400	100	400	100	400	100	-	-	-	-	
VVF42.15-2.5	S55204-V128	15	2.5												
VVF42.15-4	S55204-V129	15	4												
VVF42.20-6.3	S55204-V130	20	6.3												
VVF42.25-6.3	S55204-V131	25	6.3												
VVF42.25-10	S55204-V132	25	10												
VVF42.32-16	S55204-V133	32	16												
VVF42.40-16	S55204-V134	40	16								400	100			
VVF42.40-25	S55204-V135	40	25												
VVF42.50-31.5	S55204-V136	50	31.5		300										
VVF42.50-40	S55204-V137	50	40												
VVF42.65-50	S55204-V138	65	50		150	50	200	80							
VVF42.65-63	S55204-V139	65	63												
VVF42.80-80	S55204-V140	80	80		75		125	50			225	50			
VVF42.80-100	S55204-V141	80	100												

Valves	Actuators				SAX.. ¹⁾	SKD..	SKB..	SAV.. ¹⁾	SKC..										
	Stroke				20 mm			40 mm											
PN 16	Positioning force				800 N	1000 N	2800 N	1600 N	2800 N										
	Data sheet				N4501	N4561	N4564	N4503	N4566										
	Stock no.	DN	k _{vs} [m ³ /h]	S _v	Δp_{max} [kPa]														
																			
-10...150 °C																			
VVF42.100-125	S55204-V142	100	125		-	-	-	-	-	-	125			250	50				
VVF42.100-160	S55204-V143	100	160																
VVF42.125-200	S55204-V144	125	200								90			160					
VVF42.125-250	S55204-V145	125	250																
VVF42.150-315	S55204-V146	150	315								60			100					
VVF42.150-400	S55204-V147	150	400																

¹⁾ Permissible medium temperature (coupled valve) -25...130 °C - up to 150 °C in horizontal mounting position

DN = Nominal size

k_{vs} = Flow nominal value of cold water (5...30 °C) through the fully opened valve (H₁₀₀) at a differential pressure of 100 kPa (1 bar)

S_v = Rangeability

Δp_s = Maximum permissible differential pressure at which the motorized valve still closes securely against the pressure

Δp_{max} = Maximum permissible differential pressure across the valve's throughport for the entire positioning range of the motorized valve

Ordering (example)

Type	Stock no.	Description
VXF42.65-63	S55204-V139	3-port valve with flange, PN 16
SKD32.50	SKD32.50	Electro-hydraulic actuator

Delivery

Valves, actuators, and accessories are packaged and delivered separately.

Note

Counter-flanges, bolts, and gaskets must be provided on site.

Equipment combinations

Type	Stock no.	Stroke	Positioning force	Operating voltage	Positioning signal	Spring return time	Positioning time	LED	Manual adjuster	Auxiliary functions			
SAX31.00	S55150-A105	20 mm	800 N	AC 230 V	3-position	-	120 s	-	Press and fix	1)			
SAX31.03	S55150-A106						30 s						
SAX61.03 SAX61.03U	S55150-A100 S55150-A100-A100			AC 24 V DC 24 V	0...10 V 4...20 mA 0...1000 Ω	-	-	x		2), 3)			
SAX81.00	S55150-A102							3-position			-	120 s	-
SAX81.03 SAX81.03U	S55150-A103 S55150-A103-A100			30 s									
SKD32.21	SKD32.21	20 mm	1000 N	AC 230 V	3-position	8 s	Opening: 30 s Closing: 10 s	-	Turn, position is maintained	1)			
SKD32.50	SKD32.50						-				120 s		
SKD32.51	SKD32.51						8 s						
SKD60	SKD60			AC 24 V	0...10 V 4...20 mA 0...1000 Ω	-	-	Opening: 30 s Closing: 15 s		x	2)		
SKD62 SKD62U	SKD62 SKD62U											15 s	
SKD62UA	SKD62UA											4)	
SKD82.50 SKD82.50U	SKD82.50 SKD82.50U			3-position	-	-	-	120 s		-	1)		
SKD82.51 SKD82.51U	SKD82.51 SKD82.51U											8 s	
SKB32.50	SKB32.50			20 mm	2800 N	AC 230 V	3-position	-		120 s	-	Turn, position is maintained	1)
SKB32.51	SKB32.51												
SKB60	SKB60	AC 24 V	0...10 V 4...20 mA 0...1000 Ω			-	-	Opening: 120 s Closing: 10 s	x	2)			
SKB62 SKB62U	SKB62 SKB62U										10 s		
SKB62UA	SKB62UA										4)		
SKB82.50 SKB82.50U	SKB82.50 SKB82.50U	3-position	-			-	-	120 s	-	1)			
SKB82.51U SKB82.51	SKB82.51 SKB82.51U										10 s		
SAV31.00	S55150-A112	40 mm	1600 N	AC 230 V	3-position	-	120 s	-	Press and fix	1), 5)			
SAV61.00 SAV61.00U	S55150-A110 S55150-A110-A100			AC 24 V DC 24 V				0...10 V 4...20 mA 0...1000 Ω		x	1), 2), 5), 6)		
SAV81.00 SAV81.00U	S55150-A111 S55150-A111-A100									-	1), 5)		

Type	Stock no.	Stroke	Positioning force	Operating voltage	Positioning signal	Spring return time	Positioning time	LED	Manual adjuster	Auxiliary functions
SKC32.60	SKC32.60	40 mm	2800 N	AC 230 V	3-position	-	120 s	-	Turn, position is maintained	1)
SKC32.61	SKC32.61					18 s				
SKC60	SKC60			AC 24 V	0...10 V 4...20 mA 0...1000 Ω	-	Opening: 120 s Closing: 20 s	x		2)
SKC62 SKC62U	SKC62 SKC62U					20 s				
SKC62UA	SKC62UA			3-position		-	120 s	-		1)
SKC82.60 SKC82.60U	SKC82.60 SKC82.60U					-				
SKC82.61 SKC82.61U	SKC82.61 SKC82.61U					18 s				

1) Auxiliary switch, potentiometer

4) Plus sequence control, stroke limitation, selection of acting direction

2) Position feedback, forced control, selection of valve characteristic

5) Stem heating element (optional)

3) Optional: sequence control, selection of acting direction



6) Function module (optional)

Accessories / Spare parts

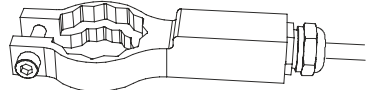
Accessories

Type	Stock no.	Description	Notes	Example
ASZ6.6	S55845-Z108	Stem heating element	Required for medium temperatures < 0 °C	

Spare parts

Stem sealing gland				
Type	DN	Stock no.	Notes	Image
VVF42..	DN 15...80	4 284 8806 0	Series A	 4 284 8806 0
VXF42..	DN 100...150	4 284 8806 0	Series A, B and C until October 2015	
	DN 100...150	4 679 5629 0	Series D as of October 2015	
VVF42..K	DN 50...80	4 284 8806 0	Series A, B	 4 679 5629 0
	DN 100...150	4 284 8806 0	Series A	
	DN 100...150	4 679 5629 0	Series B	

Product documentation

Title	Content	Document ID
Mounting instructions valves VVF.. VXF..	Mounting instructions	M4030 74 319 0749 0
Valves VVF...,VXF...,VVG41..., VXG41..., VVI41..., VXI41..	Basic documentation: Contains background information and general technical basics for valves	P4030

Technical and mechanical design

The illustrations below show the basic design of the valves. Constructional features, such as the shape of plugs, may differ.

2-port valves

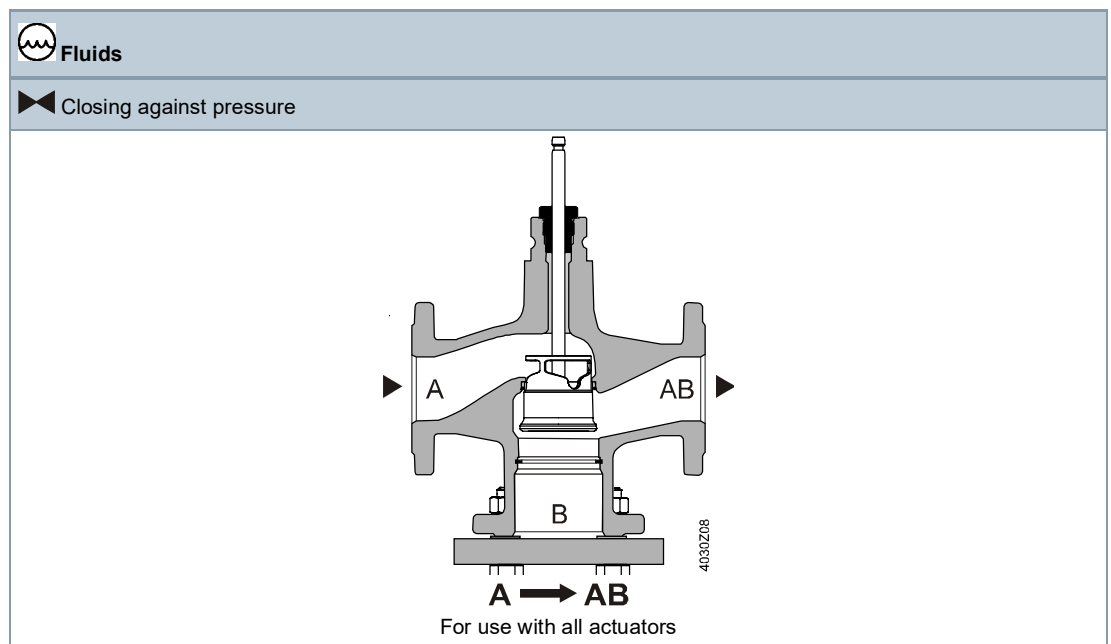

2-port valves pressure compensated

The VVF42..K valves use a pressure compensated plug. This enables the same type of actuators to be used for the control of volumetric flow at higher differential pressures.

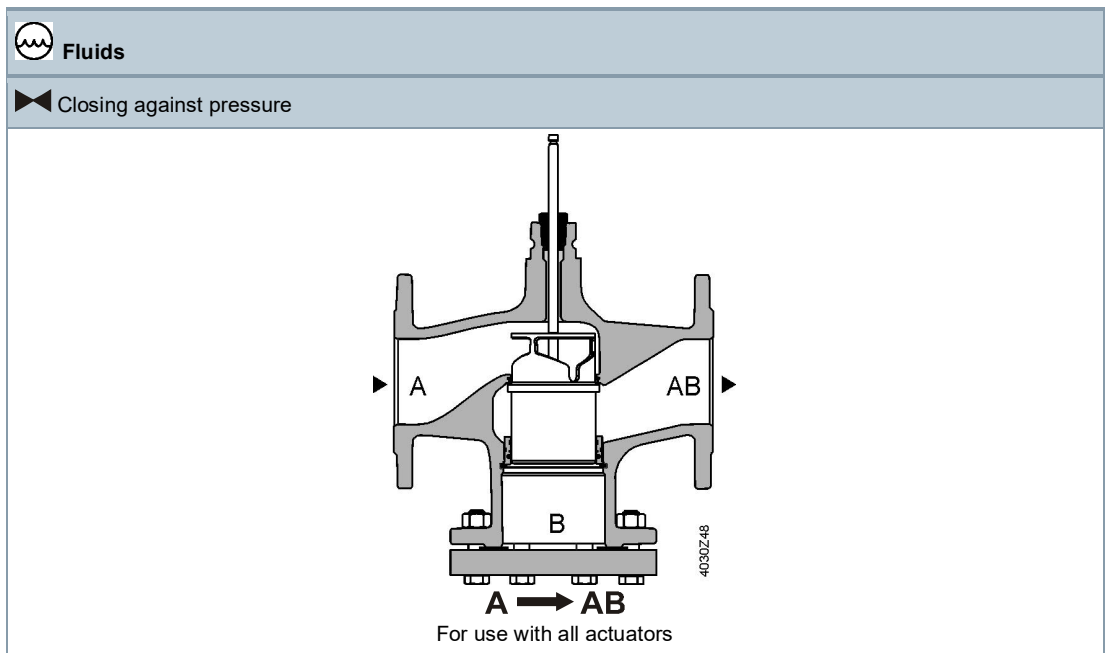

Note

2-port valves do not become 3-port valves by removing the blank flange!

3-port valves

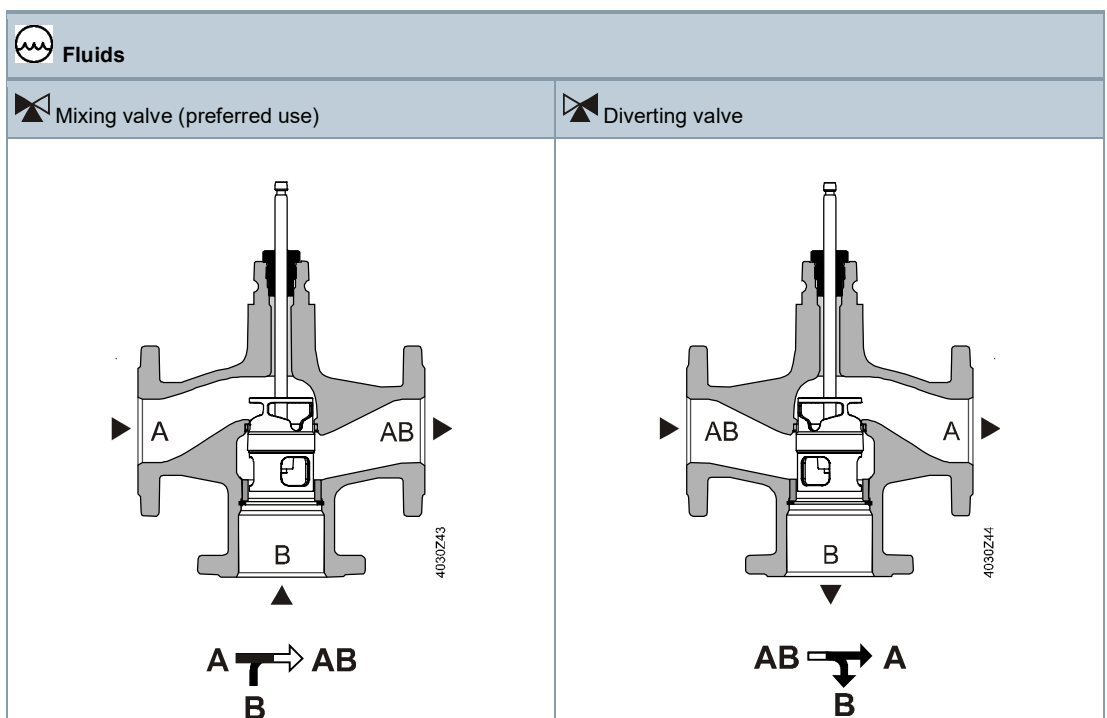

Sizing

Flow chart

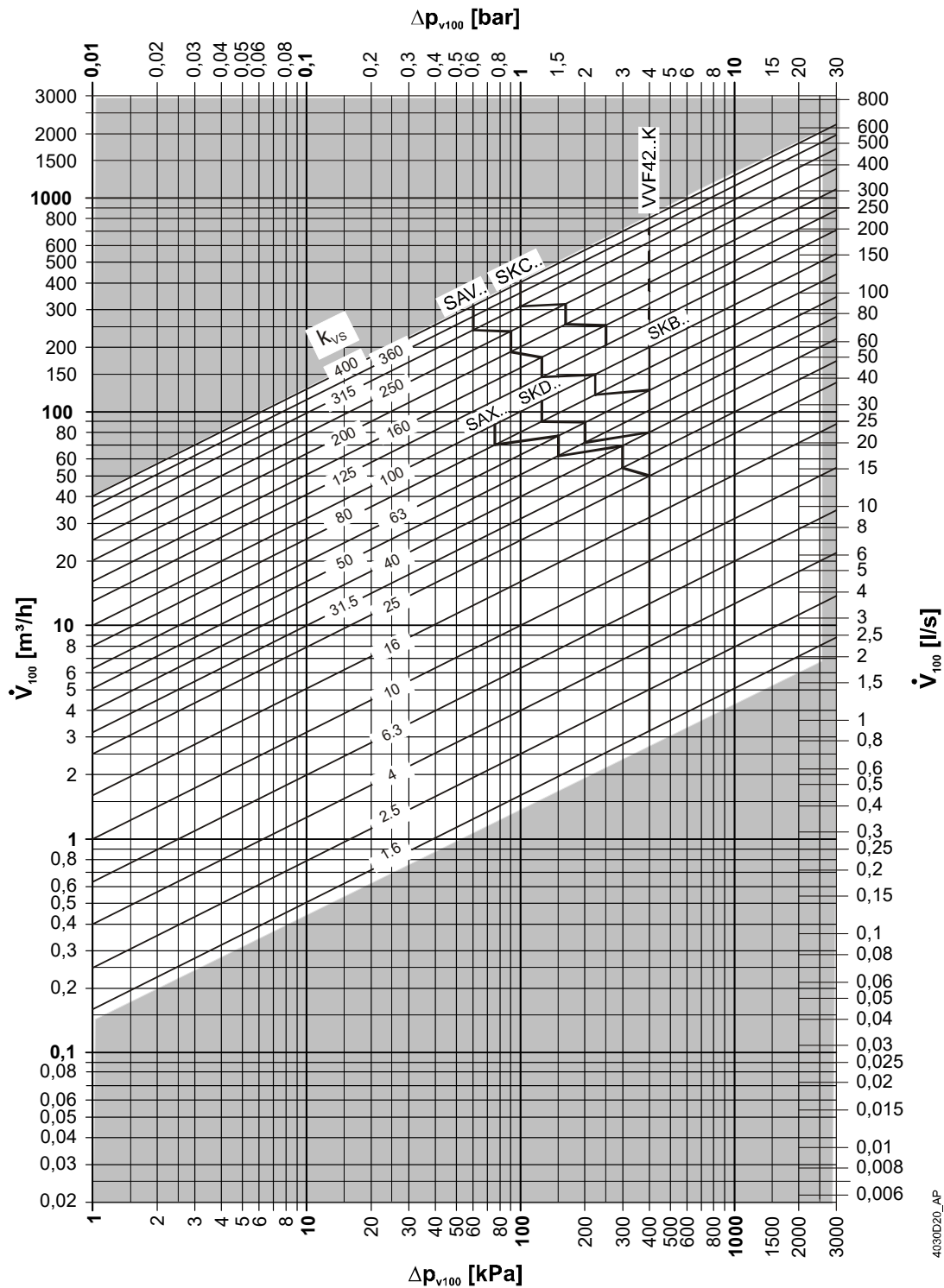

Δp_{max} values apply for the mixing function. Δp_{max} values for diverting function, see "Type summary", page 2 [▶ 2].

Valve characteristics

2-port valves

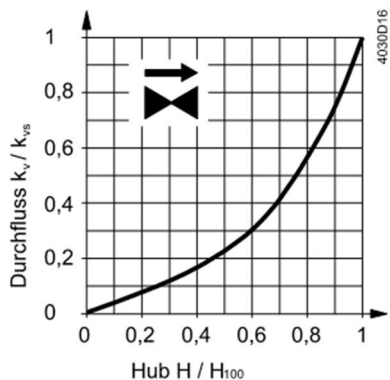

0...30 %: Linear

30...100 %: Equal percentage
 $n_{gl} = 3$ to VDI / VDE 2173

For high k_{vs} values the valve characteristic is optimized for maximum volumetric flow k_{v100} .

For product lines:
 VVF42.125-250
 VVF42.125-250K
 VVF42.150-400
 VVF42.150-360K

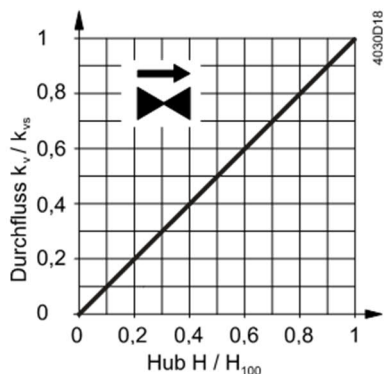

0...100 %: Linear

3-port valves

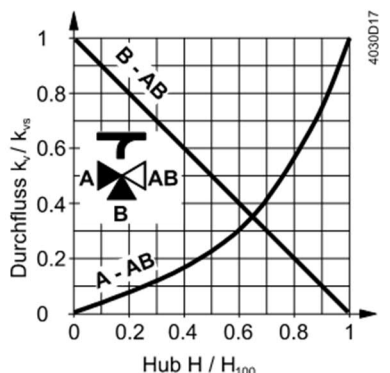

Throughport A-AB

0...30 %: Linear

30...100 %: Equal percentage
 $n_{gl} = 3$ to VDI / VDE 2173

For high k_{vs} values the valve characteristic is optimized for maximum volumetric flow k_{v100} .

Bypass B-AB

0...100 %: Linear

Tor AB = constant flow

Tor A = variable flow

Tor B = bypass (variable flow)

Mixing: Flow from port a and port B to port AB

Diverting: Flow from port AB to port A and port B

For product lines:
VXF42.125-250
VXF42.150-400

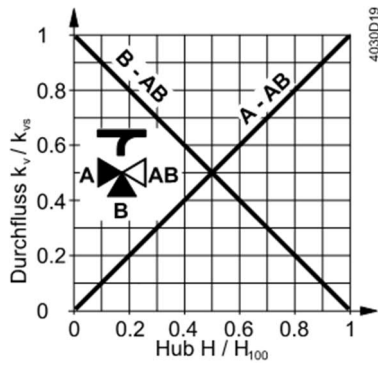

Throughport A-AB

0...100%: Linear

Bypass B-AB

0...100%: Linear

Operating pressure and medium temperature Fluids, PN16 with V..F42..

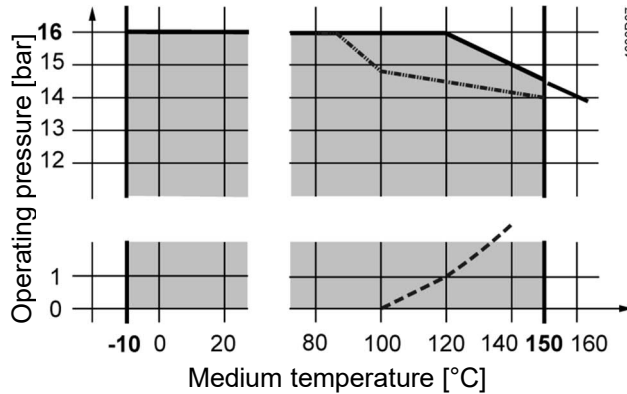

Curve for saturated steam; steam forms below this line



Operating pressure according to EN 1092-1, valid for 2-port valves with blank flange

Operating pressure and operating temperatures according to ISO 7005, EN 1092, and EN 12284

Notes

All relevant local directives must be observed.

Medium compatibility and temperature ranges

Medium	Temperature range		Type			Notes
	T _{min} [°C]	T _{max} [°C]	VVF42..	VVF42..K	VXF42..	
Cold water	1	25	x	x	x	-
Low-temp. hot water	1	130	x	x	x	-
High temp. hot water ¹⁾	130	150	x	x	x	-
	150	180	-	-	-	-
Water with antifreeze	-5	150	x	x	x	For medium temperatures below 0 °C, the stem heating ASZ6.6 has to be installed.
	-10	150	x	- ³⁾	x	
	-20	150	-	-	-	
Cooling water ²⁾	1	25	-	-	-	-
Brines	-5	150	x	x	x	For medium temperatures below 0 °C, the stem heating ASZ6.6 has to be installed.
	-10	150	x	- ³⁾	x	
	-20	150	-	-	-	

Medium	Temperature range		Type			Notes
	T _{min} [°C]	T _{max} [°C]	VVF42..	VVF42..K	VXF42..	
Super-clean water (demineralized and deionized)	1	150	-	-	-	
Demineralized water according to VDI2035 / SWKI_BT102-01	1	150	x	x	x	

- 1) Differentiation due to saturated steam curve
- 2) Open circuits
- 3) VVF42..K valves cannot be used with media below -5 °C due to the compensation sealing material.

Fields of use

Fields of use		Type		
		VVF42..	VVF42..K	VXF42..
Generation	Boiler plants	x	x	x
	District heating plants	x	x	-
	Refrigeration plants	x	x	x
Distribution	Heating groups	x	x	x
	Ventilation and air-handling units	x	x	x

Notes

Engineering

Mounting location

Preferably mount the valves at the return, as the temperature is lower there and the strain on the stem sealing gland is lower.

Dirt trap

Mount a dirt filter or dirt trap before the valve to ensure the proper functioning and long service life of the valve. Remove dirt, welding beads, etc. from the valves and pipes.

Cavitation

Cavitation can be avoided by limiting the pressure differential across the valve depending on the medium temperature and prepressure.

Mounting

Mounting position

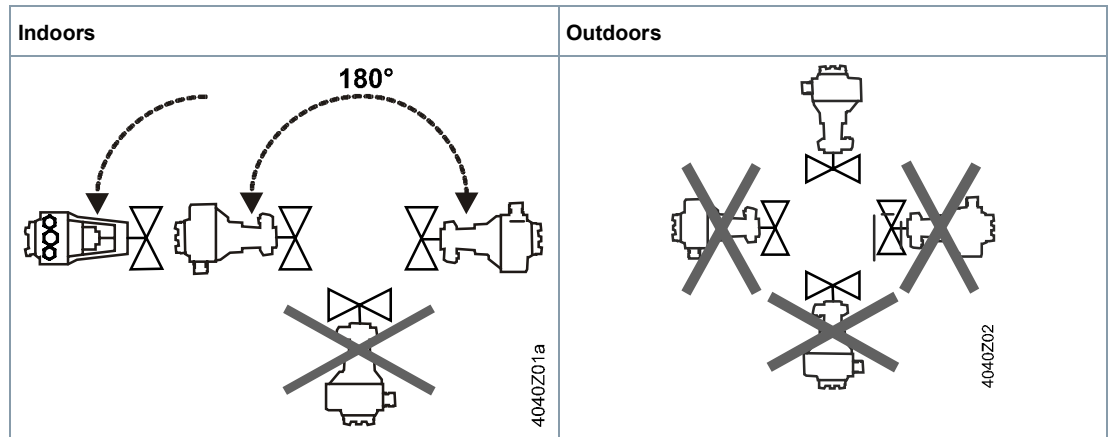

Mounting positions apply to both 2- and 3-port valves.

Commissioning



The valve may be put into operation only if actuator and valve are correctly assembled.

Note

Ensure that the actuator stem and valve stem are rigidly connected in all positions.

Function check

Valve	Throughport A->AB	Bypass B->AB
Valve stem extends	Closes	Opens
Valve stem retracts	Opens	Closes

Maintenance

The valves are equipped with maintenance-free, continuously lubricated stem sealing glands. See Accessories / Spare parts [► 6] for replacement stem sealing glands.

CAUTION



When servicing valves or actuators:

- Deactivate the pump and turn off the power supply.
 - Close the shutoff valves.
 - Fully reduce the pressure in the piping system and allow pipes to completely cool down.
- If necessary, disconnect the electrical wires.

Disposal

Do not dispose of the valve as part of domestic waste.

- Special treatment for individual components may be required by law or make ecological sense.
- Comply with all local and currently applicable laws and regulations.

Warranty

Application-related technical data are guaranteed only when the valves are used in connection with the Siemens actuators listed under "Type summary" and "Equipment combinations". When used with actuators of other manufacture, any warranty by Siemens becomes void.

Functional data		
PN class		PN 16
Connection		Flange
Operating pressures		See section "Operating pressure and medium temperature", page 11
Valve characteristic ¹⁾		See section "Valve characteristics", page 10
Leakage rate	Throughport	0...0.02% of k_{VS} value
	Bypass	0.5...2% of k_{VS} value ($k_{VS} \geq 6.3$) 0.5...3% of k_{VS} value (k_{VS} 1.6; 2.5; 4)
Permissible media		See table "Medium compatibility and temperature ranges", page 11
Medium temperatures		-10...150 °C
	VVF42..K	-5...150 °C
Rangeability	To DN 25	> 50
	From DN 32	>100
Nominal stroke	To DN 80	20 mm
	From DN 100	40 mm

Materials			
Valve body		EN-GJL-250	
Blank flange	VVF..	S235JRG2	
Valve stem		Stainless steel	
Seat		Machined	
Plug	VVF.., VXF..		Brass / bronze
	VVF..K..:	DN65, DN80	Brass / bronze
		DN50, DN100...150	Stainless steel
Stem sealing gland		Brass EPDM O-rings PTFE sleeve silicone-free grease	
Compensation sealing		Stainless steel FEPM (silicone-free)	

Standards, directives and approvals		
Pressure Equipment Directive		PED 2014/68/EU
Pressure-carrying accessories		Scope: Article 1, section 1 Definition: Article 2, section 5
Fluid group 2:		PN 16
	≤ DN 50	Without CE certification as per article 4, section 3 (sound engineering practice) ²⁾
	DN 65...125	Category I, Module A, with CE-marking as per article 14, section 2

Standards, directives and approvals		
	DN 150	Category II, Module A2, with CE-marking as per article 14, section 2 notified body number 0036
EU conformity (CE)	DN 65...150	A5W00006523 ³⁾
PN class		ISO 7268
Operating pressure		ISO 7005, DIN EN 12284
Flanges		ISO 7005
Length of flanged valves		DIN EN 558-1, line 1
Valve characteristic		VDI 2173
Leakage rate		Throughport, bypass according to EN 60534-4 / EN 1349
Water treatment		VDI 2035

Environmental conditions		
Storage		IEC 60721-3-1
	Class	1K3
	Temperature	-15...55 °C
	Rel. humidity	5...95 % r.h.
Transport		IEC 60721-3-2
	Class	2K3, 2M2
	Temperature	-30...65 °C
	Rel. humidity	< 95 % r.h.
Operation		IEC 60721-3-3
	Class	3K5, 3Z11
	Temperature	-15...+5 °C
	Rel. humidity	5...95 % r.h.

Environmental compatibility
The product environmental declarations CE1E4403en01 ³⁾ , CE1E4403en02 ³⁾ und CE1E4403en03 ³⁾ contain data on environmentally compatible product design and assessments (RoHS compliance, materials composition, packaging, environmental benefit, disposal).

Dimensions / Weight
See "Dimensions", [▶ 17]

- 1) For certain valve lines and high k_{vs} values, the valve characteristic is optimized for maximum volumetric flow K_{V100} .
- 2) Valves where $PS \times DN < 1000$ do not require special testing and cannot carry the CE label.
- 3) The documents can be downloaded from <http://www.siemens.com/bt/download>.

VVF42..
VVF42..K

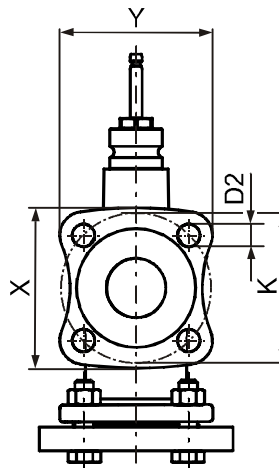
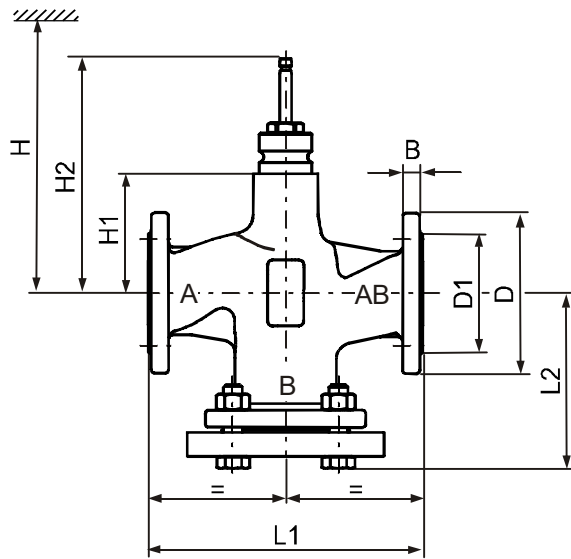

DN 15..DN 65

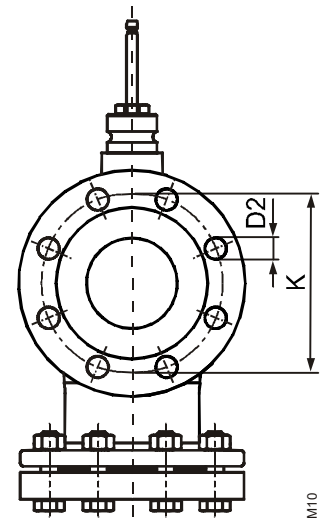

DN 80..DN 150

4030M10

Type	DN	kg	B	Ø D	Ø D1	Ø D2	L1	L2	X	Y	Ø K	H1	H2	H				
														SAX..	SKD..	SKB..	SAV..	SKC..
VVF42..	15	3.7	14	95	46	14 (4x)	130	86	79	76	65	37	133.5	479	537	612	-	-
	20	4.7	16	105	56	14 (4x)	150	97	86.6	83	75	37	133.5	479	537	612	-	-
	25	5.4	15	115	65	14 (4x)	160	106.5	94.4	90.1	85	37	133.5	479	537	612	-	-
	32	8.4	17	140	76	19 (4x)	180	119	115.6	110.7	100	37	133.5	479	537	612	-	-
	40	9.3	16	150	84	19 (4x)	200	126	123.2	117.8	110	37	133.5	479	537	612	502	-
	50	12.2	16	165	99	19 (4x)	230	144	135.2	128.4	125	50	146.5	492	550	625	525	-
	65	17	17	185	118	19 (4x)	290	174	150	142.5	145	75	171.5	517	575	650	540	-
	80	25	17	200	132	19 (8x)	310	186	-	-	160	75	171.5	517	575	650	540	-
	100	35.9	17	220	156	19 (8x)	350	205	-	-	180	110	226.5	-	-	-	575	685
	125	52.5	17	250	184	19 (8x)	400	233	-	-	210	123	239.5	-	-	-	588	698
VVF42..K	150	74.9	17	284	211	23 (8x)	480	275.5	-	-	240	150.5	267	-	-	-	616	726
	50	12	16	165	99	19 (4x)	230	144	135.2	128.4	125	50	146.5	492	550	625	-	-
	65	17.7	17	185	118	19 (4x)	290	174	150	142.5	145	75	171.5	517	575	650	-	-
	80	26.8	17	200	132	19 (8x)	310	186	-	-	160	75	171.5	517	575	650	-	-
	100	35.3	17	220	156	19 (8x)	350	206	-	-	180	110	226.5	-	-	-	575	685
	125	51.6	17	250	184	19 (8x)	400	233	-	-	210	123	239.5	-	-	-	588	698
	150	74.8	17	284	211	23 (8x)	480	275.5	-	-	240	150.5	267	-	-	-	616	726
																	652	762

VXF42..

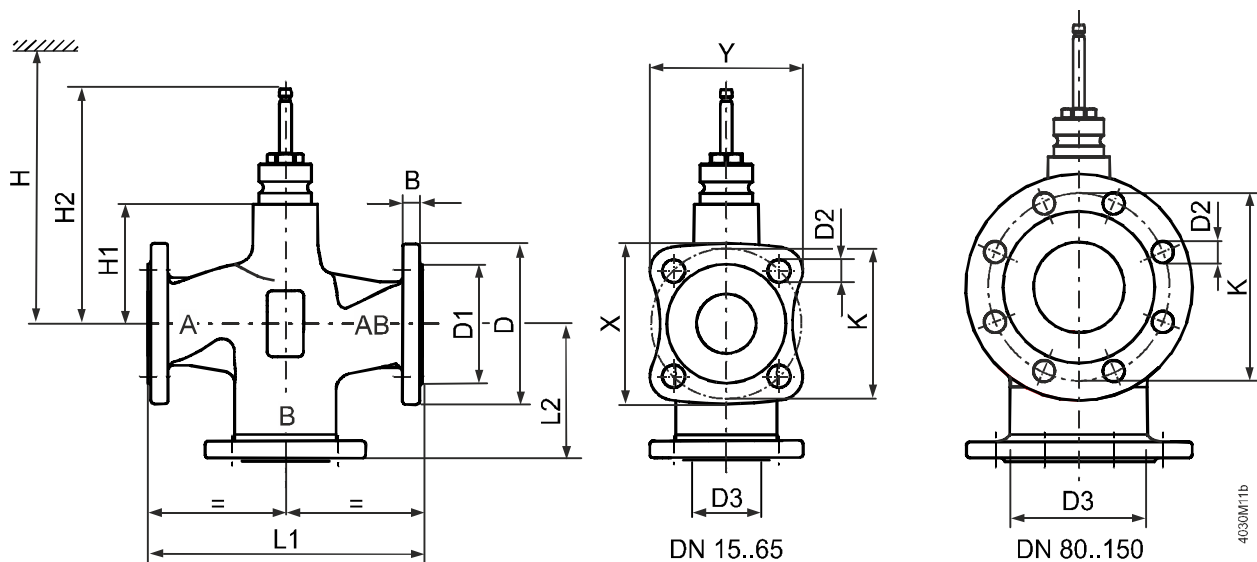

4030M11b

Type	DN	kg	B	Ø D	Ø D1	Ø D2	Ø D3 ¹⁾	L1	L2	X	Y	Ø K	H1	H2	H				
															SAX..	SKD..	SKB..	SAV..	SKC..
VXF42..	15	2.6	14	95	46	14 (4x)	23	130	65	79	76	65	37	133.5	479	537	612	-	-
	20	3.3	16	105	56	14 (4x)	29	150	75	86.6	83	75	37	133.5	479	537	612	-	-
	25	3.8	15	115	65	14 (4x)	36	160	80	94.4	90.1	85	37	133.5	479	537	612	-	-
	32	5.7	17	140	76	19 (4x)	46	180	90	115.6	110.7	100	37	133.5	479	537	612	-	-
	40	6.3	16	150	84	19 (4x)	56	200	100	123.2	117.8	110	37	133.5	479	537	612	502	-
	50	8.7	16	165	99	19 (4x)	69	230	115	135.2	128.4	125	50	146.5	492	550	625	525	-
	65	12.9	17	185	118	19 (4x)	85	290	150	150	142.5	145	75	171.5	517	575	650	540	-
	80	19.2	17	200	132	19 (8x)	102	310	155	-	-	160	75	171.5	517	575	650	540	-
	100	29	17	220	156	19 (8x)	124	350	175	-	-	180	110	226.5	-	-	-	575	685
	125	43.2	17	250	184	19 (8x)	149	400	200	-	-	210	123	239.5	-	-	-	588	698
	150	62.1	17	284	211	23 (8x)	174	480	240	-	-	240	150.5	267	-	-	-	616	726
												186.5	303				652	762	

1) Interior opening of the bypass port

Revision numbers

Type	Valid from rev. no.	Type	Valid from rev. no.
VVF42.15-1.6	..A	VXF42.15-1.6	..A
VVF42.15-2,5	..A	VXF42.15-2.5	..A
VVF42.15-4	..A	VXF42.15-4	..A
VVF42.20-6.3	..A	VXF42.20-6.3	..A
VVF42.25-6.3	..A	VXF42.25-6.3	..A
VVF42.25-10	..A	VXF42.25-10	..A
VVF42.32-16	..A	VXF42.32-16	..A
VVF42.40-16	..A	VXF42.40-16	..A
VVF42.40-25	..A	VXF42.40-25	..A
VVF42.50-31.5	..A	VXF42.50-31.5	..A
VVF42.50-40	..A	VXF42.50-40	..A
VVF42.65-50	..A	VXF42.65-50	..A
VVF42.65-63	..A	VXF42.65-63	..A
VVF42.80-80	..A	VXF42.80-80	..A
VVF42.80-100	..A	VXF42.80-100	..A
VVF42.100-125	..D	VXF42.100-125	..D
VVF42.100-160	..D	VXF42.100-160	..D
VVF42.125-200	..D	VXF42.125-200	..D
VVF42.125-250	..D	VXF42.125-250	..D
VVF42.150-300	..D	VXF42.150-300	..D
VVF42.150-400	..D	VXF42.150-400	..D
VVF42.50-40K	..B		
VVF42.65-63K	..A		
VVF42.80-100K	..A		
VVF42.100-160K	..B		
VVF42.125-250K	..B		
VVF42.150-360K	..B		

Issued by
Siemens Switzerland Ltd
Smart Infrastructure
Global Headquarters
Theilerstrasse 1a
CH-6300 Zug
+41 58 724 2424
www.siemens.com/buildingtechnologies

© Siemens Switzerland Ltd, 2013
Technical specifications and availability subject to change without notice.

Document ID CE1N4403en
Edition 2021-10-29