



Series WD3 Water Leak Detector

Specifications - Installation and Operating Instructions



WD3-BP



WD3-LP

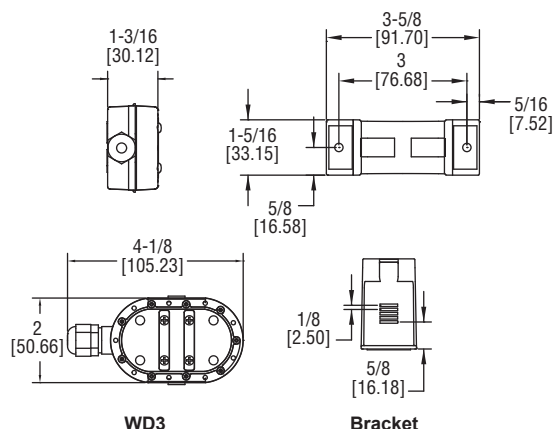

WD3

Bracket

The Series WD3 Water Leak Detector protects equipment from water damage by detecting the presence of water in drip pans in air handler units, under raised floors in data centers, or on floors around sump pumps and drains. Water is detected once it reaches a level that bridges the two conductive strips on the bottom of the housing. Depending on the model ordered, audible and visual alerts provide local indication of the alarm condition and an internal switch will give remote indication or control to prevent further build up of water.

For applications where power is not available, the Model WD3-BP-D1-A is battery powered. Otherwise, either AC or DC supply voltages can be used to power the water detector. The sensing height can be adjusted to as low as 1/32" using the included adjustable mounting bracket. The mounting bracket can attach to any flat surface by either using the attached adhesive strips or mounting screws.

INSTALLATION

Mounting

The Series WD3 mounts horizontally using an adjustable mounting bracket that allows detection from 1/32" up to 17/32". The tabs on the side of the water detector fit into the slots on the bracket as shown in Figure 1. The mounting bracket mounts to the drip pan or flat surface by either the attached adhesive strips or using two #6 or #8 screws.



Figure 1: Mounting WD3 to Mounting Bracket

NOTICE

Before attaching the mounting bracket to the desired surface, the Series WD3 will need to be attached to the mounting bracket. The adhesive is very strong and is not easily removed once attached.

SPECIFICATIONS

Service: Water or conductive fluids.

Minimum Sensing Gap: 1/32".

Switch Type: Battery Powered Models: SPST NO SSR; External Powered Models: DPDT relay.

Electrical Ratings:

Battery Powered Model: Pilot duty rating 250 mA @ 24 VDC;

External Powered Models: 1A @ 24 VAC/DC.

Audible Alarm: At least 85 dB @ 1 foot distance (depends on model).

Visual Alarm: Red LED for water level; Yellow LED for low battery (battery powered models only); Green LED for power condition (external powered models only).

Temperature Limits: 32 to 122°F (0 to 50°C).

Power Requirements:

Battery Powered Model: 3V CR2450 lithium metal battery, installed functional,

user replaceable;

External Powered Models: 11 to 27 VAC/DC.

Power Consumption:

Battery Powered Model: 0.9 mA steady state / 3.0 mA during alarm condition;

External Powered Models: 30 mA steady state / 85 mA during alarm condition.

Battery Life: 5 years steady state / 48 hours during alarm condition.

Electrical Connections: 4.9' (1.5 m), 22 AWG, PVC, UL plenum rated cable.

Enclosure Material: ABS and polycarbonate with flammability classification UL 94 V-0.

Enclosure Rating:

Audible Alarm Models: Water-tight up to 3/4 of the body height;

Non-Audible Alarm Models: NEMA 6P (IP 68) submersible.

Weight: 4.85 oz (137.5 g).

Agency Approvals: CE, RoHS.

Replacing Batteries (Battery Powered Model Only)

When the battery is low, a yellow warning LED will begin to flash and an audible alarm will sound every 300 seconds to alert that it is time to change the battery. Using a large flat head screw driver, turn the battery cover 1/4 turn in the direction of the arrows on the cover. Remove the battery cover by lifting it up. Remove the coin cell battery from its compartment. Insert a new 3V CR2450 coin cell battery in the compartment with the positive (+) side of the battery facing up. Replace the battery cover and twist the cover using the large flat head screw driver in the opposite direction of the arrows on the cover.

Model	Output	Power	Audible Alarm
WD3-BP-D1-A	SPST NO SSR	Battery	Yes
WD3-LP-D2	DPDT Relay	11 to 27 VAC/DC	No
WD3-LP-D2-A	DPDT Relay	11 to 27 VAC/DC	Yes

Wiring

The wires in the 4.9 ft (1.5 m) cable for the Series WD3 are color coded to reduce wiring errors. For battery powered models, Figure 2 has the wiring diagram. For external powered models, Figure 3 has the wiring diagram.

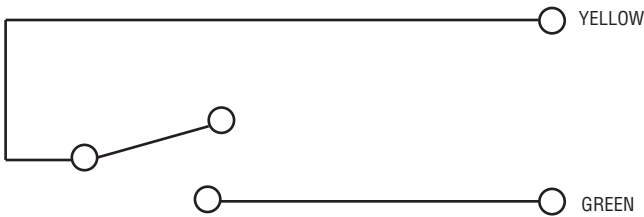

Figure 2: Wiring for WD3-BP-D1-A

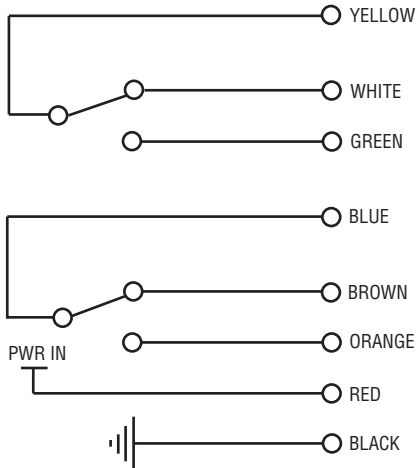

Figure 3: Wiring for WD3-LP-D2 and WD3-LP-D2-A

Operation

After mounting and wiring the Series WD3, it is ready for operation. The water is detected when it bridges the two conducting strips on the bottom of the unit. Upon detecting water, the relay contact will close and a red LED will begin to flash. On models with the built in annunciator, the annunciator will begin to chirp until the water bridge between the conducting strips evaporates. After water evaporates, the relay contacts will return to their normal state.

LED Indicators

For Model WD3-LP-D2 and WD3-LP-D2-A
 Green – On when power is supplied to the unit
 Red – On when water is detected

For Model WD3-BP-D1-A
 Yellow – On when low battery condition is detected
 Red – On when water is detected

MAINTENANCE/REPAIR

Upon final installation of the Series WD3 no routine maintenance is required. The Series WD3 is not field serviceable with the exception of replacing the batteries on battery powered model and should be returned if repair is needed. Field repair should not be attempted and may void warranty.

WARRANTY/RETURN

Refer to “Terms and Conditions of Sales” in our catalog and on our website. Contact customer service to receive a Return Goods Authorization number before shipping the product back for repair. Be sure to include a brief description of the problem plus any additional application notes.