

ML7430E/ML7435E ELECTRIC LINEAR ACTUATORS FOR MODULATING CONTROL

SPECIFICATION DATA



FEATURES

- 0...10 Vdc / 2...10 Vdc signal input
- Fast run-time
- Low power consumption
- Quick and easy installation
- No separate linkage required
- No calibration
- Force-limiting end switches
- Spring return (ML7435E)
- Manual operator
- Synchronous motor
- Direct / reverse action adjustable
- Maintenance-free

SPECIFICATIONS

Temperature Limits

Ambient operating limits	0...+50 °C at 5 to 95% rh
Ambient storage limits	-40...+70 °C at 5 to 95% rh
Medium valve temperature	Max. +130 °C

Signals

Input voltage range	Y = 0...10 Vdc or 2...10 Vdc
Input resistor	$R_i = 100 \text{ k}\Omega$
Signal source output register	Max. $1 \text{ k}\Omega$

Safety

Protection standard	IP54 as per EN60529
Protection class	II as per EN60730-1
Flame retardant	V0 as per UL94 (optional with metal cable gland)

Wiring

Terminals	1.5 mm ²
Cable entry	M20x1.5

Weight

0.37 kg / 0.5 kg

Dimensions

See Fig. 2 and Fig. 3

Material

Cover	ABS-FR
Base	Glass fiber reinforced plastic

GENERAL

The ML7430E and ML7435E Electric Linear Actuators are designed to provide modulating control in closed control loops together with the small linear valves V5832B/V5833A (DN25...DN40) and V5825B/V5872B for high-differential pressure.

These valve-actuator combinations are suitable especially for integration into compact or conventional stations for direct or indirect district heating connections, air handling units and roof top units for zone control, and domestic hot water applications.

The actuators are microprocessor-controlled for exact positioning. The direction of movement is reversible. The V5825B or V5872B valve and ML7435B actuator combination provides safe close-off function and is approved according to DIN32730.

OS-number	ML7430E1005	ML7435E1004
supply voltage	24 Vac -15/+20%, 50/60 Hz	
power consumption	4 VA	5 VA
signal input 0(2) Vdc *	actuator stem retracts	
signal input 10 Vdc *	actuator stem extends	
nominal stroke	6.5 mm	
run-time at 50 Hz	15 s	60 s
nominal stem force	400 N	
spring return time	-	≈15 s
spring return direction	-	actuator stem retracts at power failure

* = factory setting

OPERATION

General

The drive of a synchronous motor is converted into linear motion of the actuator stem by using a spur gear transmission. Actuator and valve are directly connected by a nut.

An integrated mechanism limits the stem force. Installed microswitches switch off the actuator precisely when the specified stem force is reached.

The close-off position is self-adjusting by means of an automatic synchronization function. Synchronization is performed when the applied control signal is 0 V or 10 V. The actuator then checks its end position every 20 minutes. Any manual operation will be detected within 20 minutes, at the latest, and the actuator will return to its end position after that control cycle.

Manual Operation for ML7430E

The actuators are equipped with a manual operator. Manual operation is possible only after the power supply has been switched off or disconnected. It should be used only to check the valve operation. To operate, turn the manual operator knob clockwise to move the stem downward and counter-clockwise to move the stem upward.

Manual Operation for ML7435E

The actuators are equipped with a manual operator (for 8 mm Hex Key). Manual operation is possible only after the power supply has been switched off or disconnected. It disables the actuators safety function and should be used only to check the valve operation.

The manual operator is located under the cover.

Electrical Installation

NOTE: To avoid the voltage drop influence of the cabling, it is recommended that you wire control signal Y and 24 V \perp separately from power supply wiring.

Input Signal Range

The range of the analog input signal Y (0...10 Vdc or 2...10 Vdc) can be selected by changing the position of jumper plug W2 (see Fig. 1). The factory set is at 0...10 Vdc.

Direction of Action

The direction of action (direct or reverse) can be selected by changing the position of jumper plug W1 (see Fig. 1). It is set by the factory such that the stem extends at increasing signal and retracts at decreasing signal (direct action).

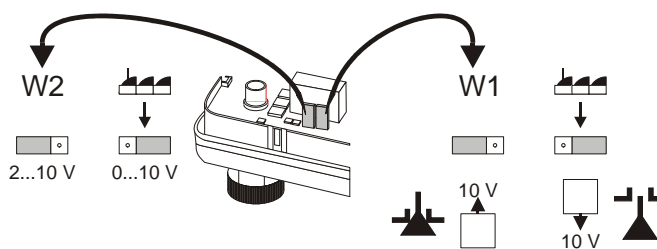

Fig. 1. Jumper plugs W1 and W2

NOTE: Jumper plugs W1 and W2 are accessible after the cover has been removed (see Fig. 1).

Y-Signal Override

To override the Y-signal and force the actuator in 0% or 100% stroke position, inputs 1 and 2 (see Fig. 4) must be connected as follows:

- 0% stroke position (stem fully retracted):
24 V \perp applied to input Y
- 100% stroke position (stem fully extended):
24 V \sim applied to input Y
- or vice versa if reverse action is selected

Y-Signal break

In the event of a wire break at the Y-signal input, the actuator is moved into the 0 V signal position (safety position).

Suitable Valves

	DN15	DN20	DN25	DN32	DN40	order no.
close-off pressure in kPa	1600	--	1600	--	--	V5872B
	-	--	1600	1200	1000	V5832B
	-	--	1600	1200	1000	V5833A
	2500	2500	2500	2500	--	V5825B

Approvals

NOTE: Actuator ML7435E1004 in combination with the following valves is approved according to DIN 32730:

valve OS-no.	DIN registration no.
V5872B	1F15299
V5825B	1F15903

Spare Parts

actuator	spare parts	
	name	order no.
ML7430E1005	motor assembly	43196492-001
	circuit board	43196493-001
ML7435E1004	motor assembly	43196492-001
	circuit board	43196493-002

DIMENSIONS

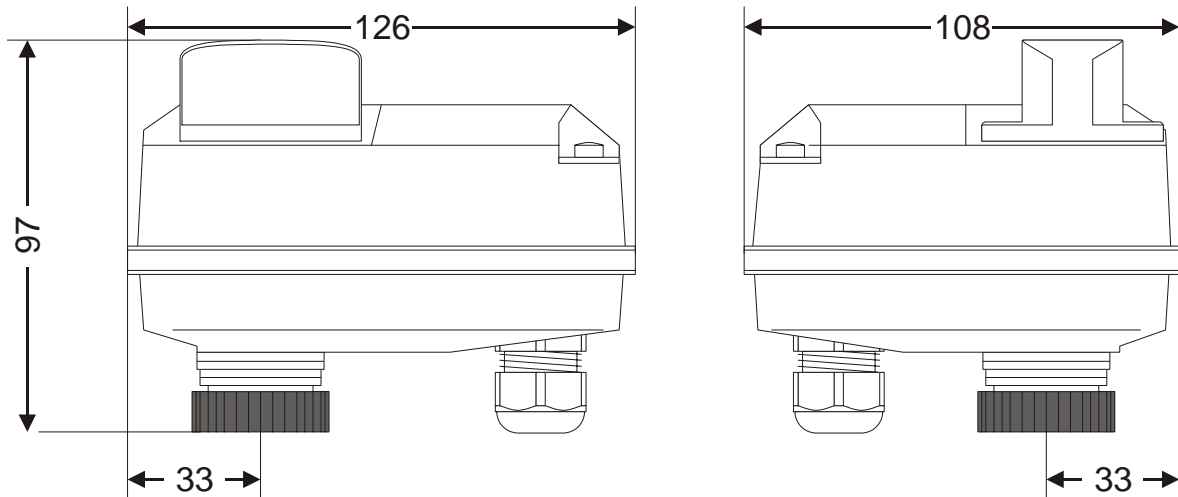

Fig. 2. ML7430E (dimensions in mm)

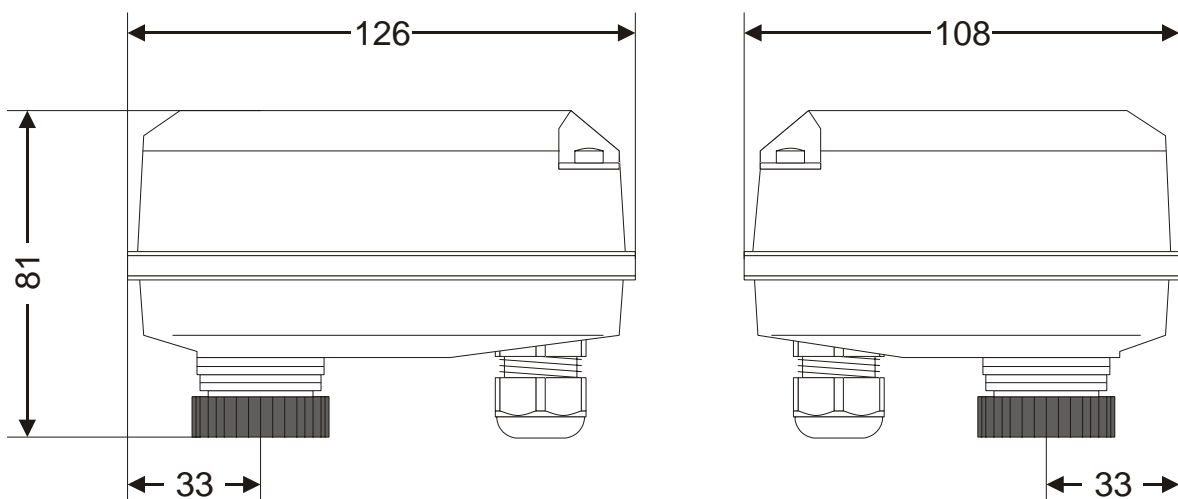

Fig. 3. ML7435E (dimensions in mm)

WIRING

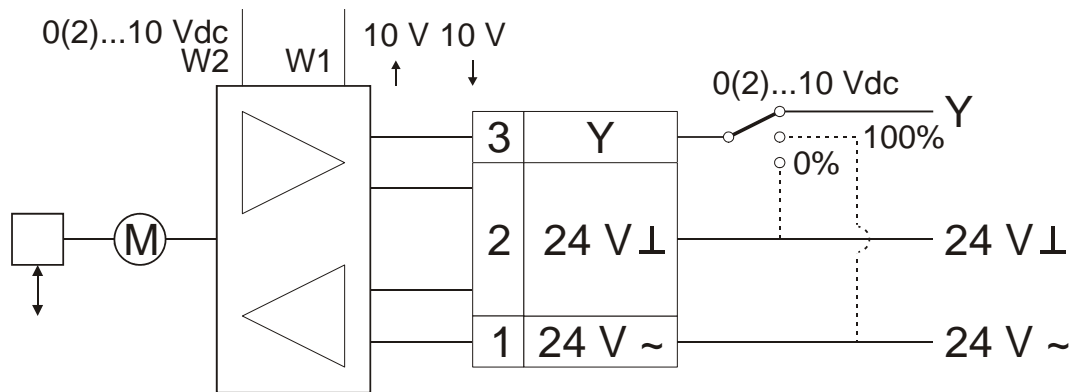

Fig. 4. Wiring

Honeywell

Manufactured for and on behalf of the Environmental and Combustion Controls Division of Honeywell Technologies Sarl, Ecublens, Route du Bois 37, Switzerland by its Authorized Representative:

Automation and Control Solutions

Honeywell AG
 Böblinger Straße 17
 D-71101 Schönaich
 Phone: (49) 7031 63701
 Fax: (49) 7031 637493
<http://europe.hbc.honeywell.com>

Subject to change without notice. Printed in Germany

Manufacturing location certified to

DIN EN ISO
9001/14001

EN0B-0260GE51 R0306